

LONCIN LC2P73F MAINTENANCE MANUAL



Quick Links

[Part I Technical Specifications](#)

[Technical Parameters](#)

[Electric Wiring Diagram](#)

[Change Engine Oil](#)

Table of Contents

Table of Contents

Part I Technical Specifications

Introduction of engine

Technical parameters

Model installation dimensional drawing

dimensional drawing

Electric wiring diagram

Part II Repair Instructions

Maintenance precautions

Marking position of machine No

Maintenance standards

Torque parameters of fasteners

Part III Maintenance

Table of maintenance periods

Change engine oil

Maintenance of air filter

Maintenance of spark plug

Adjustment of valve clearance

Adjustment of idle speed

Adjustment of speed regulator

Electric Starter

Storage of engine

Part IV Faults Diagnosis

Difficulty of engine in starting

Underpower of engine

Rotating speed instability of engine

Abnormal exhaust colors of engine

Engine is easily to be flameout

Engine has no high speed

Overheat of engine

Abnormal noises of engine

Fault of electric starting system

Check the cylinder pressure

Detection of spark

Part V Disassembly & Repair

Precautions on disassembly/assembly

Disassembly

Assembly

Disassembly and maintenance of engine

Air filter

Fan cover

Control level

Carburetor

Flywheel and ignition coil

Cylinder head and valve

Speed-regulating arm, breather slot

Crankcase cover and governor

Crankcase, crankshaft and piston

Other ManualsLib Projects



LC2P73F

LC2P76F

Maintenance Manual



LONCIN MOTOR CO., LTD.

SAFETY INFORMATION

Before operating and maintaining the engine, please carefully read and understand the Maintenance Manual. To use the machine safely and efficiently, you must conduct proper maintenance and operation to the machine.

The following identifications throughout the Manual may give prompts to operators and maintainers as well as illustrate matters that cause dangers.

⚠ DANGER *The identification reminds you to note that it may cause severe personal injury or death which is imperative.*

⚠ WARNING *The identification reminds you to note that it may cause severe personal injury or death or improper operation.*

⚠ CAUTION *This identification reminds you to note that it may cause personal injury or property damage or improper operation.*

Be vigilant to fuel oil, exhaust emissions and moving parts to avoid severe personal injury or death.

Add fuel carefully!

- Gasoline is inflammable. Please add the fuel oil in the outdoor, well-ventilated area after the engine is stopped.
- It is prohibited to smoke when adding gasoline and be away from flame and spark.
- It is prohibited to start the engine before the gasoline splashed area is dry.

Heat Exhaust

- The temperature of silencer can be very high during the operation of engine; even if the

machine is stopped for a moment, it would be hot. Be careful not to touch the burning silencer. Prior to maintenance, the engine shall be placed indoor and cooled down.

- To prevent fire, when the engine is working, the distance between the engine and the wall shall be kept at least 1 m. Inflammables must be away from the engine.

Carbon Monoxide Poisoning

- The exhaust contains poisonous carbon monoxide. Avoid inhaling the exhaust.
- Don't use indoors.
- Don't operate the engine in the closed garage or enclosed area.

General Precautions

- Carefully read the Maintenance Manual, get familiar with all the control mechanisms and the correct using and maintenance & installing method of the machine and master the operating method of stopping and fast separating the machine.
- When you feel fatigue, have discomfort or have a drink, please don't operate the engine; otherwise, it may cause severe injury.
- Children and people who don't read the Manual or without training are prohibited to use the engine.
- Don't repair the machine without mastering the method of engine repair.
- Don't refit the machine or change its structure. Once the machine loses its balance, it may easily cause damages and injury incidents.

Contents

Part I Technical Specifications

1-1 Introduction of engine.....	1
1-2 Technical parameters	2
1-3 Model installation dimensional drawing.....	3
1-4 P.T.O dimensional drawing	4
1-5 Electric wiring diagram	5

Part II Repair Instructions

2-1 Maintenance precautions	6
2-2 Marking position of machine No.	7
2-3 Maintenance standards.....	8
2-4 Torque parameters of fasteners.....	10

Part III Maintenance

3-1 Table of maintenance periods	11
3-2 Change engine oil	12
3-3 Maintenance of air filter	13
3-4 Maintenance of spark plug.....	14
3-5 Adjustment of valve clearance.....	15
3-6 Adjustment of idle speed	15
3-7 Adjustment of speed regulator	16
3-8 Electric Starter	16
3-9 Storage of engine	17

Part IV Faults Diagnosis

4-1 Difficulty of engine in starting	18
4-2 Underpower of engine.....	19
4-3 Rotating speed instability of engine	20
4-4 Abnormal exhaust colors of engine.....	21
4-5 Engine is easily to be flameout.....	22
4-6 Engine has no high speed	22
4-7 Overheat of engine	23
4-8 Abnormal noises of engine.....	24
4-9 Fault of electric starting system.....	25

Contents

4-10 Check the cylinder pressure	26
4-11 Detection of spark	26
Part V Disassembly & Repair	
5-1 Precautions on disassembly/assembly	27
5-1-1 Disassembly	27
5-1-2 Assembly.....	27
5-2 Disassembly and maintenance of engine.....	28
5-2-1 Air filter	28
5-2-2 Fan cover	29
5-2-3 Control level.....	30
5-2-4 Carburetor	31
5-2-5 Flywheel and ignition coil.....	34
5-2-6 Cylinder head and valve	38
5-2-7 Speed-regulating arm, breather slot.....	43
5-2-8 Crankcase cover and governor	44
5-2-9 Crankcase, crankshaft and piston	47

Part I Technical Specifications

1-1 Introduction of engine

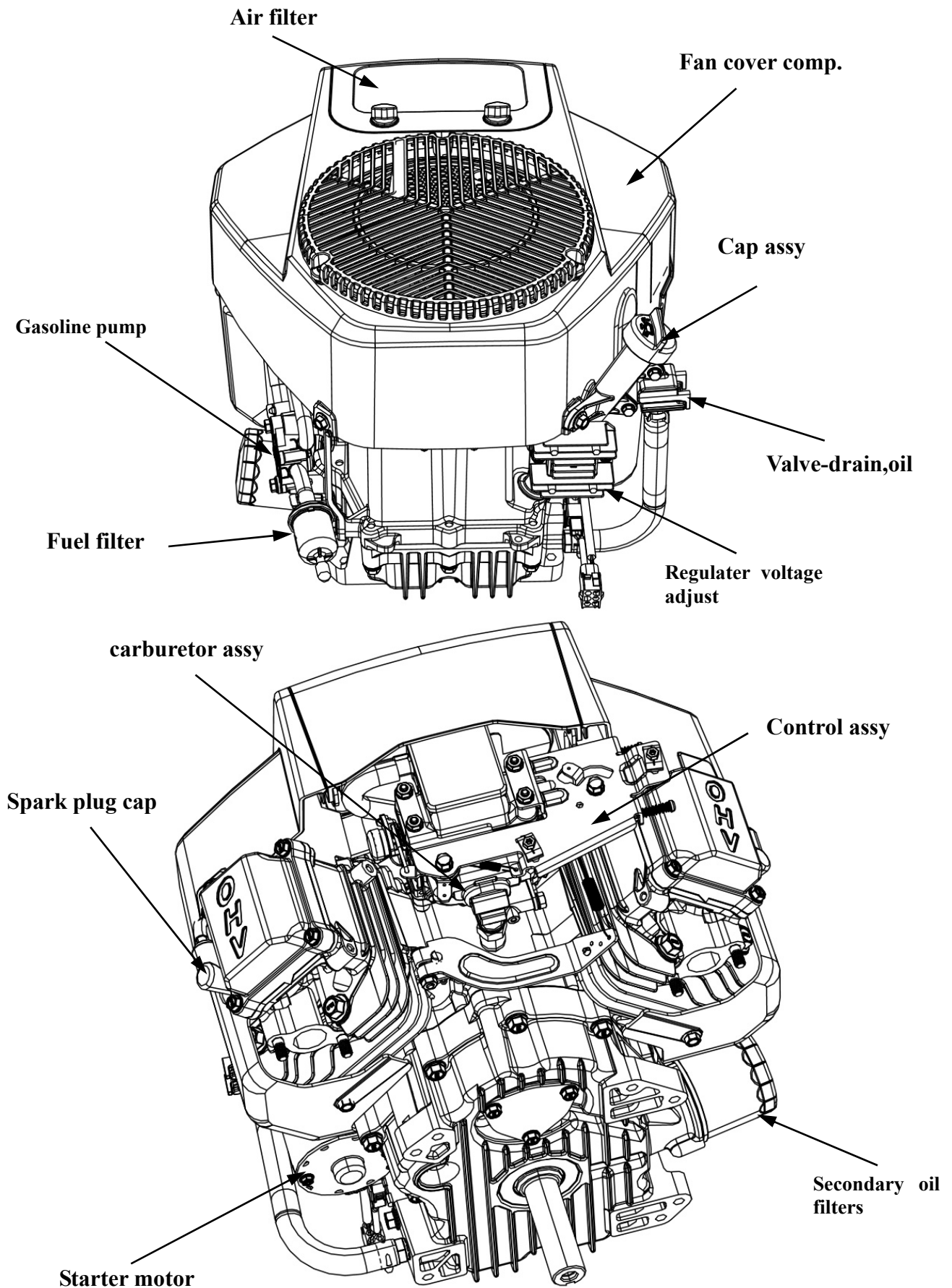

Part I Technical Specifications

1-2 Technical parameters

Model	2P73F	2P76F
Type	OHV、 V-twin Cylinders、 Forced air cooling 、 4-Stroke	
Max. power(kW/3600rpm)	14.17 /3600	14.92/3600
Net. Power (kW/rpm)	12.5/3600	13.5/3600
Max . torque (N·m/rpm/min)	37.0/(2400~2600)	40.0/(2400~2600)
Idle speed	1850±150 rpm	
Bore X Stroke(mm)	73×70	76×70
Displacement(cc)	586	635
Compression Ratio	8.7 :1	
Lubricating mode	splash+pressure lubrication	
Starting mode	Electric start	
Rotation	Anti-clockwise(from P.T.O. side)	
Valve clearance	input valve: 0.10~0.15mm, output valve: 0.10~0.15mm	
Spark plug clearance	0.7~0.8mm	
Igniting mode	Transistorized magneto Ignition	
Air cleaner	Foam & paper	
Fuel type	Unleaded gasoline, minimum 90 RON	
Oil capacity (L)	1.7	
Dimension(L×W×H)(mm)	430×420×332	
Net weight (kg)	36	36

The rated power of the engine indicated in the Manual is the net output power (net power) at 3,600 rpm of an engine under the production status measured in accordance with SAE J1349. For mass production engines, the value may vary.

The actual power of engine installed on the terminal may vary in output, which depends on several factors including the rotating speed of engine during practical use, environmental conditions, maintenance and other variants.

Part I Technical Specifications

1-3 Model installation dimensional drawing

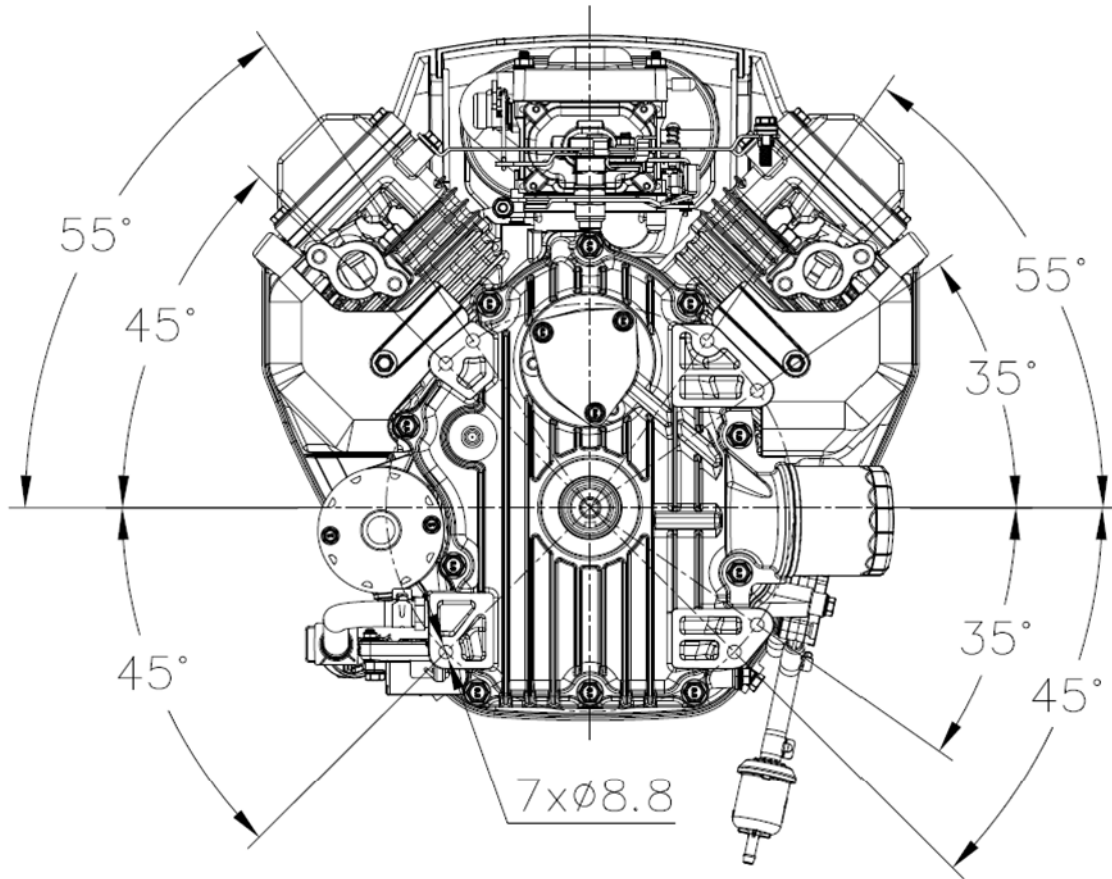

Part I Technical Specifications

1-4 P.T.O dimensional drawing

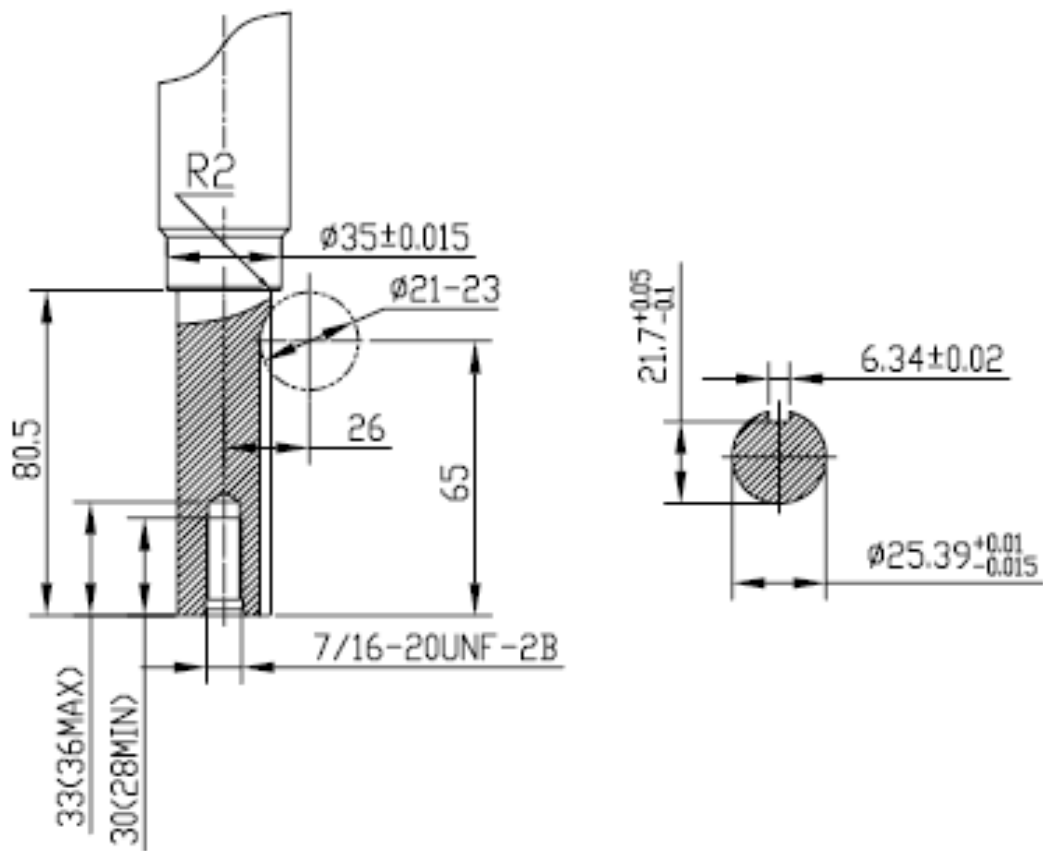

Shaft A/Type A

Part I Technical Specifications

1-5 Electric wiring diagram

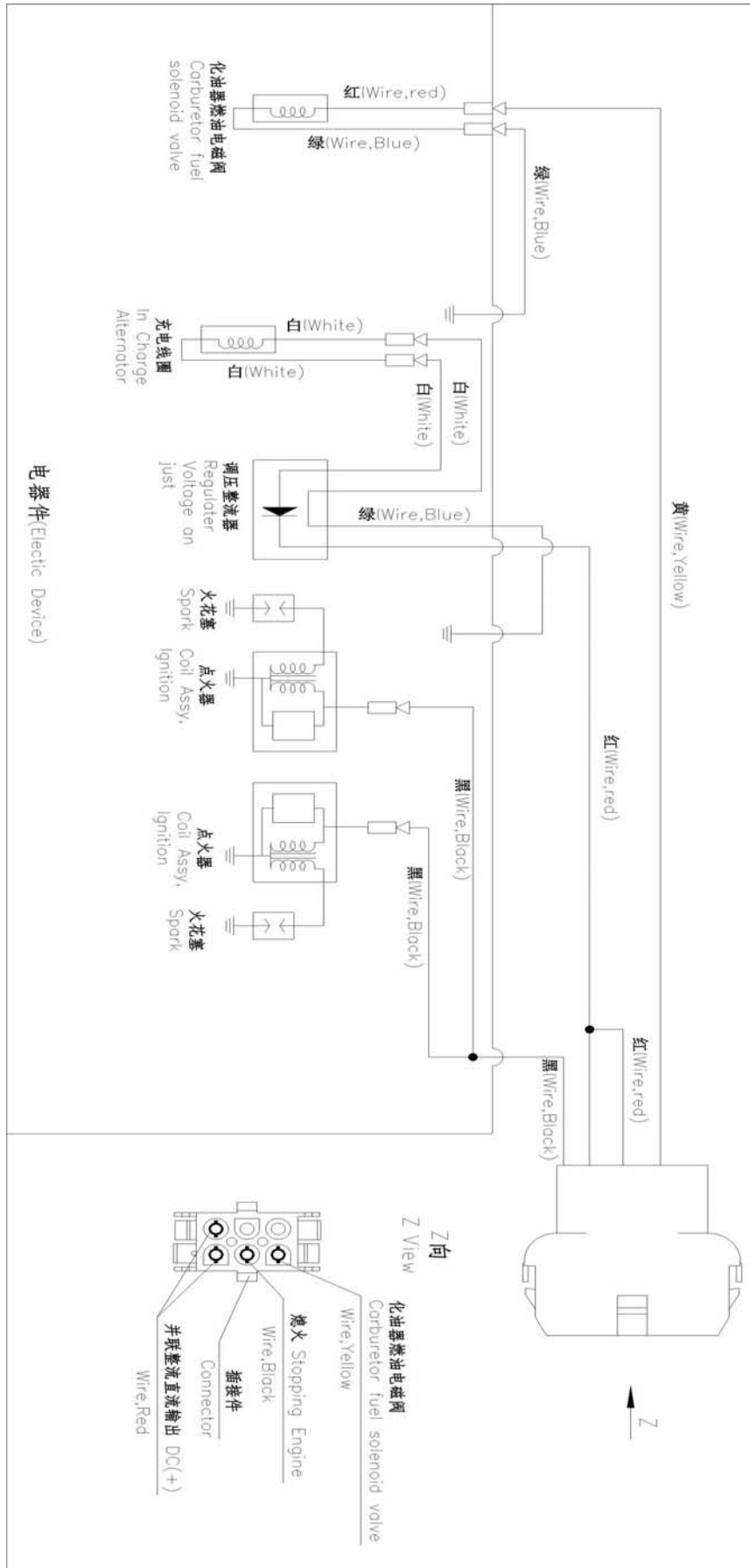

Part II Repair Instructions

2-1 Maintenance Precautions

1. Use pure LONCIN parts or the specified parts and lubricating oil. Parts not meeting LONCIN's design specifications may damage the device or the engine.

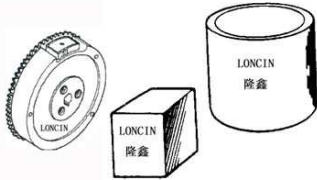

2. Operations requiring special tools must be completed with special tools and corresponding devices.

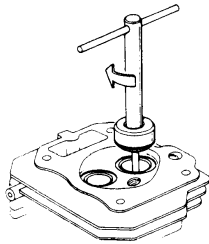

3. The washer, gasket, O-ring, oil seal, etc. shall be replaced after being dismantled.

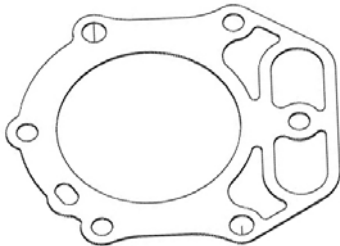

4. When fastening bolts, nuts and screws, fasten them in an order from larger diameter to smaller one and from inside to outside in a crossing way to the specified torque.

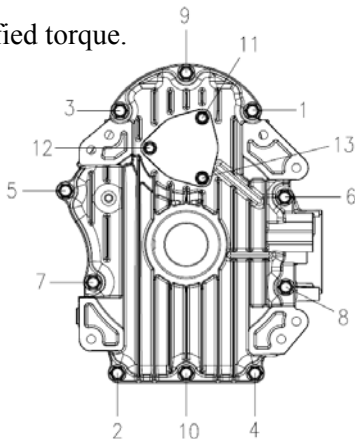

5. Parts shall be cleaned after being dismantled and shall be coated with oil on the sliding surface during assembly.

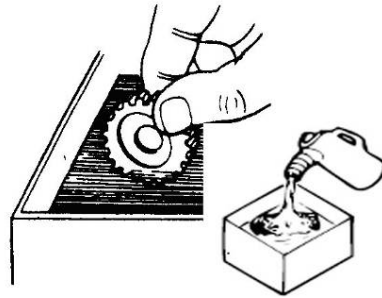

6. Fastening places and action status must be checked after the assembly.



7. The engine shall be shut down when it is under check and maintenance. Operation shall be done after the engine is completely cooled down. Operation in high temperature of the engine may cause accidents such as burning injuries.

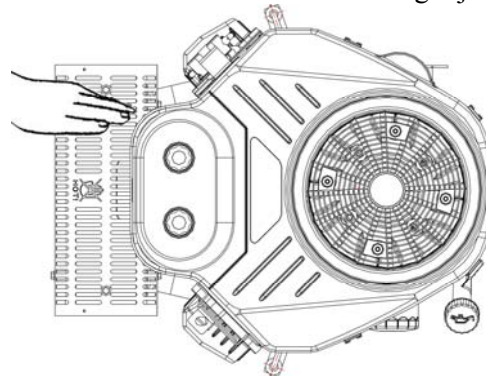

8. After maintenance, if it needs to carry out running test on the operation site, please note full ventilation. In addition, fire must be prohibited near inflammables such as fuel and grease.

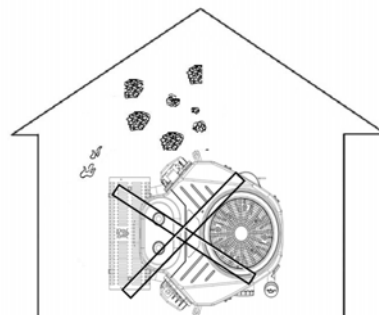

Part II Repair Instructions

Follow up the guidance indicated by the signs below:



Coat oil at the indicated position.



Operate with special tools.



Coat grease at the indicated position.

○×○(○): the mode, length and quantity of flange bolt.

P.: the page shall be referred to.

2-2 Marking position of machine No.

Machine No. is marked on the crankcase as shown in the figure below. When LONCIN dealers require correct parts during maintenance, the machine number is used to check the engine or to order parts.

Marking position of machine No.

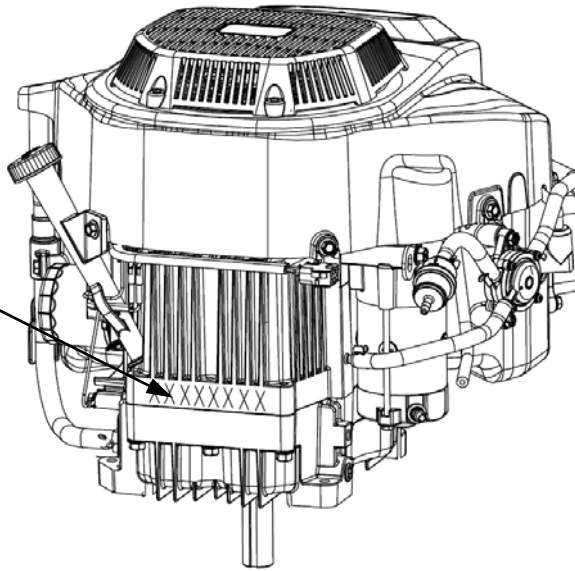

Engine No.:

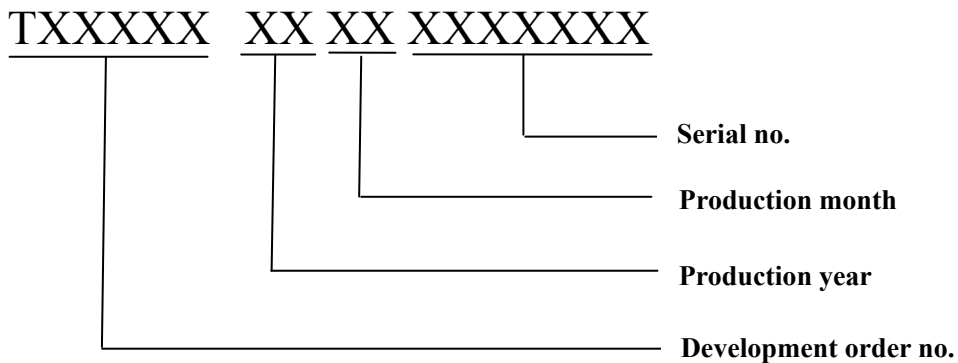

Part II Repair Instructions

2-3 Maintenance standards

Unspecified unit: mm

Part	Item	Standard	Service Limit
		LC2P73F	LC2P73F
Engine	Ile speed	(1800±150) rpm	—
Cylinder head	Warpage	—	0.05
Cylinder	Sleeve(inside diameter X)	φ 73.0~ φ 73.01	φ 73.1
	Sleeve(inside diameter Y)	φ 73.0~ φ 73.01	φ 73.1
Piston	Skirt outside diameter	φ 72.965~ φ 72.975	φ 72.755
	Clearance to cylinder	0.025~0.045	0.255
	Piston pin bore inside diameter	φ 17.002~ φ 17.008	φ 17.12
	Piston – pin clearance	0.004~0.016	0.029
Piston pin	Outside diameter	φ 16.992~ φ 16.998	φ 16.95
Piston ring	Side clearance (top/ the second)	0.02~0.06	0.11
	End gap (top)	0.15~0.30	0.40
	End gap (the second)	0.20~0.40	0.45
	Width (top)	1.17~1.19	1.1
	Width (second)	1.17~1.19	1.1
	Width (oil ring)	1.87~1.97	1.8
Connecting rod	Small end inside diameter	φ 17.006~ φ 17.017	φ 17.05
	Big end inside diameter	φ 38.015~ φ 38.025	φ 38.065
	Big end side clearance	0.024~0.059	0.145
Crankshaft	Crackpin outside diameter	φ 37.961~ φ 37.976	φ 37.92
Valve	Clearance(cold) (intake)	0.10~0.15	—
	Clearance(cold) (exhaust)	0.10~0.15	—
	Stem diameter (intake)	φ 6.565~ φ 6.58	φ 6.515
	Stem diameter (exhaust)	φ 6.545~ φ 6.56	φ 6.495
Valve guide	Inside diameter (intake, exhaust)	φ 6.6~ φ 6.615	φ 6.665
	Stem to guide clearance (intake)	0.02~0.05	0.15
	Stem to guide clearance exhaust)	0.04~0.07	0.17
Valve seat	Seat width(intake)	1.1~1.2	1.7
	Seat width (exhaust)	1.4~1.5	2.0
Valve spring	Free length	39.5~40.5	39
Cam shaft	Height (intake)	29.95~30.05	29.75
	Height (exhaust)	29.95~30.05	29.75
	Outside diameter (bearing)	φ 15.966~ φ 15.984	φ 15.916
Crankcase cover	Camshaft hole diameter	φ 16.0~ φ 16.018	φ 16.068
	Crankshaft hole diameter	φ 40.009~ φ 40.025	φ 40.075
Spark plug	Gap	(0.7-0.8)mm	—
Igniter coils	Gap to flywheel	(0.3-0.4)mm	—

* value at the speed 1400rpm of the engine.

Part II Repair Instructions

Part	Item	Standard	Service Limit
		LC2P76F	LC2P76F
Engine	Ile speed	(1800±150) rpm	—
Cylinder head	Warpage	—	0.05
Cylinder	Sleeve(inside diameter X)	φ 76.0~ φ 76.01	φ 76.1
	Sleeve(inside diameter Y)	φ 76.0~ φ 76.01	φ 76.1
Piston	Skirt outside diameter	φ 75.965 ~ φ 75.975	φ 75.755
	Clearance to cylinder	0.025 ~ 0.045	0.255
	Piston pin bore inside diameter	φ 17.002 ~ φ 17.008	φ 17.12
	Piston – pin clearance	0.004 ~ 0.016	0.029
Piston pin	Outside diameter	φ 16.992 ~ φ 16.998	φ 16.95
Piston ring	Side clearance (top/ the second)	0.02 ~ 0.06	0.11
	End gap (top)	0.15 ~ 0.30	0.40
	End gap (the second)	0.20 ~ 0.40	0.45
	Width (top)	1.17 ~ 1.19	1.1
	Width (second)	1.17 ~ 1.19	1.1
	Width (oil ring)	1.87 ~ 1.97	1.8
Connecting rod	Small end inside diameter	φ 17.006 ~ φ 17.017	φ 17.05
	Big end inside diameter	φ 38.015 ~ φ 38.025	φ 38.065
	Big end side clearance	0.024 ~ 0.059	0.145
Crankshaft	Crackpin outside diameter	φ 37.961 ~ φ 37.976	φ 37.92
Valve	Clearance(cold) (intake)	0.10 ~ 0.15	—
	Clearance(cold) (exhaust)	0.10 ~ 0.15	—
	Stem diameter (intake)	φ 6.565 ~ φ 6.58	φ 6.515
	Stem diameter (exhaust)	φ 6.545 ~ φ 6.56	φ 6.495
Valve guide	Inside diameter (intake, exhaust)	φ 6.6 ~ φ 6.615	φ 6.665
	Stem to guide clearance (intake)	0.02 ~ 0.05	0.15
	Stem to guide clearance exhaust)	0.04 ~ 0.07	0.17
Valve seat	Seat width(intake)	1.1 ~ 1.2	1.7
	Seat width (exhaust)	1.4 ~ 1.5	2.0
Valve spring	Free length	39.5 ~ 40.5	39
Cam shaft	Height (intake)	29.95 ~ 30.05	29.75
	Height (exhaust)	29.95 ~ 30.05	29.75
	Outside diameter (bearing)	φ 15.966 ~ φ 15.984	φ 15.916
Crankcase cover	Camshaft hole diameter	φ 16.0 ~ φ 16.018	φ 16.068
	Crankshaft hole diameter	φ 40.009 ~ φ 40.025	φ 40.075
Spark plug	Gap	(0.7-0.8)mm	—
Igniter coils	Gap to flywheel	(0.3-0.4)mm	—

* value at the speed 1400rpm of the engine.

Part II Repair Instructions

2-4 Torque parameters of fasteners

(1) Torque parameters of parts

No.	Process Description	Bolt Specification	Torque Range	
			N.m	In.lb.
1	Oil drain Connector	Oil drain Connector	18~23	159.3~203.5
2	Spark Plug	M14×1	25~30	221.2~265.3
3	Connecting Rod Cover	Six Hexagonal Flange Bolt M6×35	11~13	97.4~115
4	Crankcase Cover Bolt	Six Hexagonal Flange Bolt M8×45	24~32	212.4~283.2
5	Fuel Pump Assy.	Six Hexagonal Flange Bolt M6×25	6~9	53.1~79.6
6	Breather Valve Assy.	Six Hexagonal Flange Bolt M6×16	8~12	70.8~106.2
7	Cylinder Head	Six Hexagonal Flange Bolt M10×1.25×70	50~55	442.5~486.7
		Six Hexagonal Flange Bolt M10×1.25×50		
8	Push Rod Location Limit Plate	Valve Adjust Stud	28~32	247.8~283.2
9	Valve Lash Inspection (Q1)	Valve Lock Nut M6	12~16	106.2~141.6
10	Flywheel	Six Hexagonal Flange Bolt M12×35	90~115	796.5~1017
11	Ignition Coil	Six Hexagonal Flange Bolt M6×25	8~12	70.8~106.2
12	Electric Starter Motor	Six Hexagonal Flange Bolt M8×30	22~30	194.7~265.5
13	Inlet Pipe	Six Hexagonal Flange Bolt M6×35	8~12	70.8~106.2
		Stud Bolt M6×106	6~8	53.1~70.8
14	Shroud Comp	Hexagonal Flange Step Bolt 6×16.8-8×5.8	8~12	70.8~106.2
21	Charging Coil	Screw Inner Six Angle M6×25	8~12	70.8~106.2
23	Breather Valve Cover	Six Hexagonal Flange Bolt M6×16	8~12	70.8~106.2
24	Ignition Coil	Six Hexagonal Flange Bolt M6×25	8~12	70.8~106.2
25	Regulator	Six Hexagonal Flange Bolt M6×16	6~8	53.1~70.8
27	Oil Pump Cover	Six Hexagonal Flange Bolt M6×16	8~12	70.8~106.2
28	Oil Screen Cover	Six Hexagonal Flange Bolt M6×16	8~12	70.8~106.2
29	Oil Tube Plate	Six Hexagonal Flange Bolt M6×16	8~12	70.8~106.2
31	Governor Arm	Nut M6	8~12	70.8~106.2
33	Connector, Oil Filter	M20	40~45	354~398.2
34	Cylinder Head	Stud Bolt M8×34	12~16	106.2~141.6
		Nut M8	15~18	132.7~159.3
35	Oil Filter	/	9~13	79.6~115
36	Carburetor Solenoid Valve	M12	9~11	79.6~97.4

Note: for unspecified bolts and nuts in the above mentioned table, please refer to standard torques.

(2) Standard torque parameters

Fastening Parts	Bolt Specification	Torque (N.m)
Bolt and nut	5 mm Bolt and nut	4-7
	6 mm Bolt and nut	8-12
	8 mm Bolt and nut	20-28
	10 mm Bolt and nut	35-40
	12 mm Bolt and nut	50-60

Part III Maintenance

3-1 Table of maintenance periods

Maintenance schedule		Each Use	First 1 month or 5 hours	Every 3 months or 25 hours	Every 6 months or 50 hours	Every year or 100 hours	Every 2 years or 200 hours	Every 300 hours
Engine oil	Oil level	•						
	replace		•			•		
Air cleaner element	Check	•						
	Clean			•(1)				
	replace					•(1)		
Oil Filter	replace					•(2)		
Fuel filter	replace					•		
Spark plug	Clean-adjust					•		
	Replace							•
Valve clearance	Check-adjust						•(2)	
Combustion chamber	clean							•(2)
Fuel tube	replace	Each 2 years (Replace if necessary) (2)						

(1) Service more frequently when used in the dust areas.

(2) These items are to be maintained by designated dealers unless the user has special tools and skills for maintenance.

Under circumstances of frequent use, long-term use can only be guaranteed through maintenance with correct intervals specified above.

Part III Maintenance

3-2 Change engine oil

Note: drain engine oil when the machine is stopped but not cooled down so as to guarantee the fast and thorough exhaust of the oil.

The engine oil of gasoline is the main factor that affects the performance and life of gasoline. Suggest not using engine oil containing additive substance and two-stroke engine oil as they are lack of lubrication, which may shorten the service life of the gasoline.

Drain the oil while the engine is warm to assure rapid and complete draining.

1. Clean the area around the oil filler cap/dipstick and oil drain bolt. Remove the oil filler cap/dipstick.
2. Drain the engine oil into a suitable container using one of the following methods.

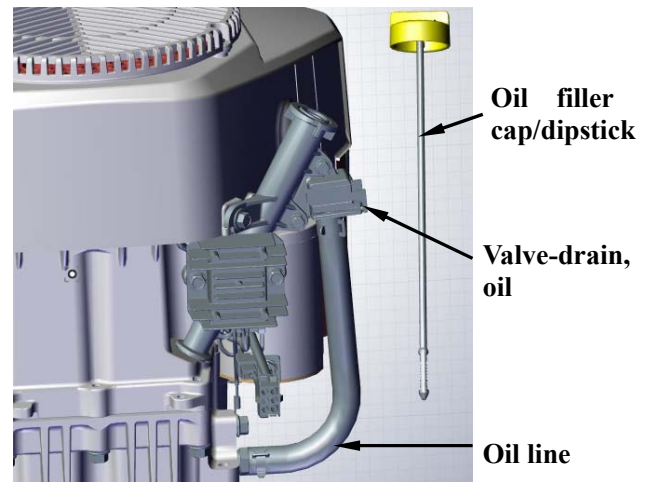

Oil drain:

- a. Unwind the tube from the cleat
- b. Pull hose down from the fitting
- c. allow the oil to drain into a suitable container.
- d. Replace hose fully

Engine oil capacities: 1.7 L

Use a high-detergent, premium quality 4-stroke engine oil certified to meet or exceed US.

Automobile manufacturers' requirements for API Service Classification SG, SF.

SAE 15W-40 is recommended for general, all-temperature use. Other viscosities shown in the chart may be used when the average temperature in your area is within the indicated range.

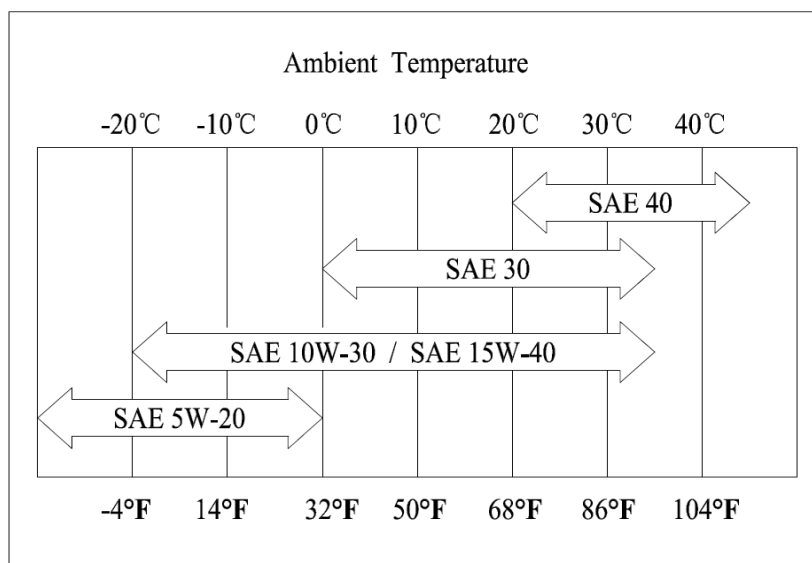

Part III Maintenance

3. Insert the oil filler cap/dipstick into the oil filler tube. Remove the oil filler cap/dipstick and check the oil level on it. Bring the level to the upper mark on the dipstick. after running the engine, recheck the oil

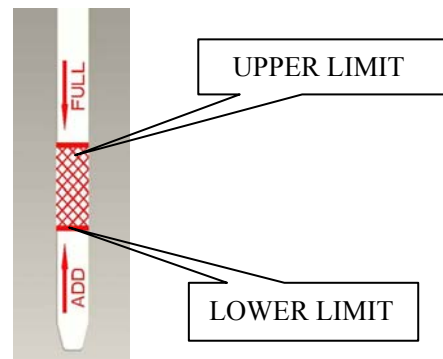

⚠ WARNING

The waste oil contains hazardous substances which may cause skin cancer for long-term exposure to the waste oil. After exposing to the waste oil, please thoroughly clean your hands with soap and clear water as soon as possible. Please dispose the waste oil and container after use in an environmental protection manner. We suggest you putting the waste oil into a sealed container and then send it to the local service station or to the waste oil recycling center.

Bear in mind: don't throw it into the garbage dump or pour it onto the ground.

3-3 Maintenance of air filter

Air inflow will be affected and the power of engine will be reduced after the filter element of the air filter gets dirty. If the operation area is full of dust, the maintenance shall be conducted more frequently.

1. Remove the wing bolt and air cleaner cover.
2. Take out filter element.

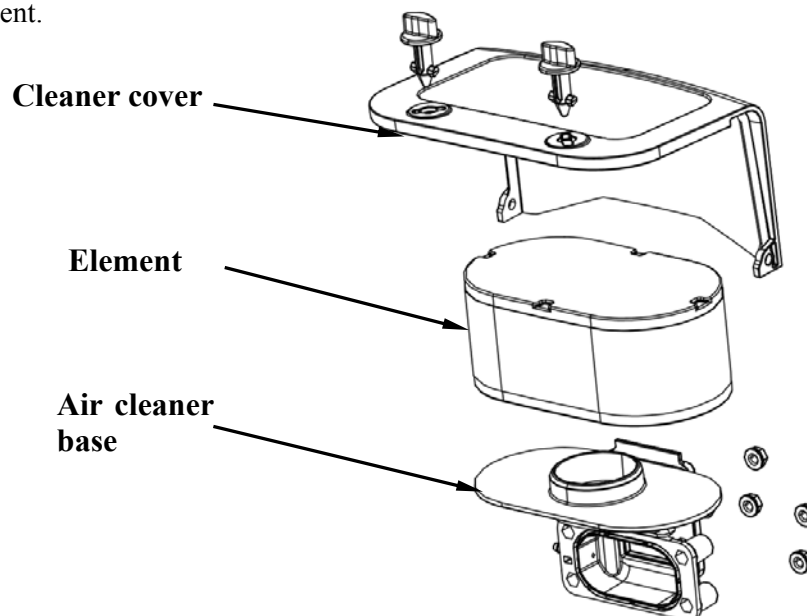

3. Clean the foam element by squeezing it in warm soapy water, rinsing it, and allowing it to dry. You may also use a nonflammable solvent and then allow it to dry.
4. Clean the paper element by tapping it on a hard surface to knock off dirt or by blowing compressed air (at less

Part III Maintenance

than 30 psi) through the filter from the inside. Never try to brush off the dirt. Brushing will force dirt into the filter fibers.

5. Use a damp rag to wipe any dirt from the inside of the air cleaner base and cover. Be careful not to allow dirt into the duct leading to the carburetor.
6. Install filter in reverse order of removal

CAUTION: *Operating the engine without an air filter, or with a damaged air filter, will allow dirt to enter the engine, causing rapid engine wear. This type of damage is not covered by the Distributor's Limited Warranty.*

3-4 Maintenance of spark plug

Recommended types: BOSCH F7RTC NHSP BP7RES
CHAMPION RN9YC

The replacement of spark plug has the following advantages:

Guarantee the continuous spark; start with more reliability; better fuel conservation

Note

The use of spark plug with incorrect models and heat values may reduce the engine performance or damage the engine.

1. Take off the spark plug cap and remove dusts around the spark plug.
2. Dismantle the spark plug with socket wrench for spark plug.
3. Check if the electrode of the spark plug is excessive worn, and if the insulator is cracked or if there is too much carbon deposition.

If it can be continuously used, use the steel wire brush to remove impurities such as carbon deposition.

4. Measure the electrode clearance of the spark plug with a feeler gauge and the correct clearance shall be 0.7 ~ 0.8 mm.

If it requires adjustment, slightly tap (when the clearance is huge) or pry the electrode with a slotted screwdriver (when

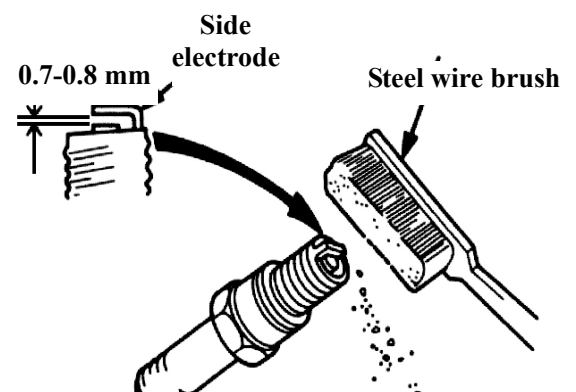
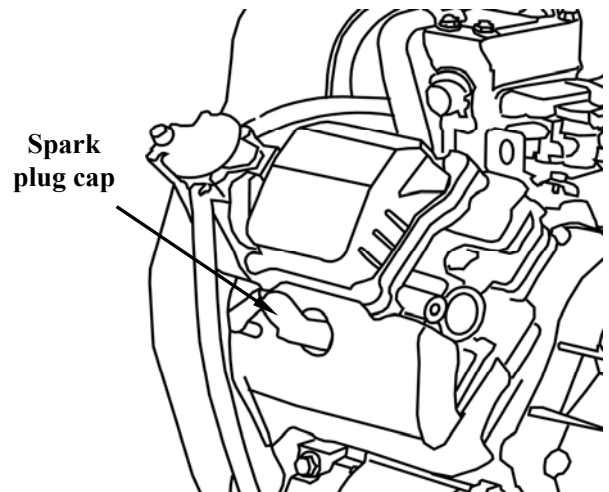

Part III Maintenance

the clearance is small).

5. Impact the gasket tightly with the socket spanner of spark plug.

When re-installing a used spark plug, screw 1/8-1/4 circle more after the gasket is impacted. When installing new spark plug, screw 1/2 circle more after the gasket is impacted.

Note

Too loose spark plug may be overheat and damage the engine. Fastening too tight may cause the spark plug mounting thread disorder inside the engine.

6. Install the spark plug cap onto the spark plug.

3-5 Adjustment of valve clearance

Valve clearance inspection and adjustment must be done with the engine cold.

1. Remove the cylinder head cover, and set the piston at top dead center of the compression stroke (both valves will be fully closed).
2. Measure the clearance between the rocker arm and the valve stem with a feeler gauge.
Intake: 0.10~0.15 mm
Exhaust: 0.10~0.15 mm
3. To adjust valve clearance, hold the rocker arm pivot and loosen the pivot lock nut.
4. Turn the rocker arm pivot to obtain the specified clearance.
5. Hold the rocker arm pivot and tighten the pivot lock nut.
6. Recheck the clearance and readjust if necessary.
7. Install the cylinder head cover.

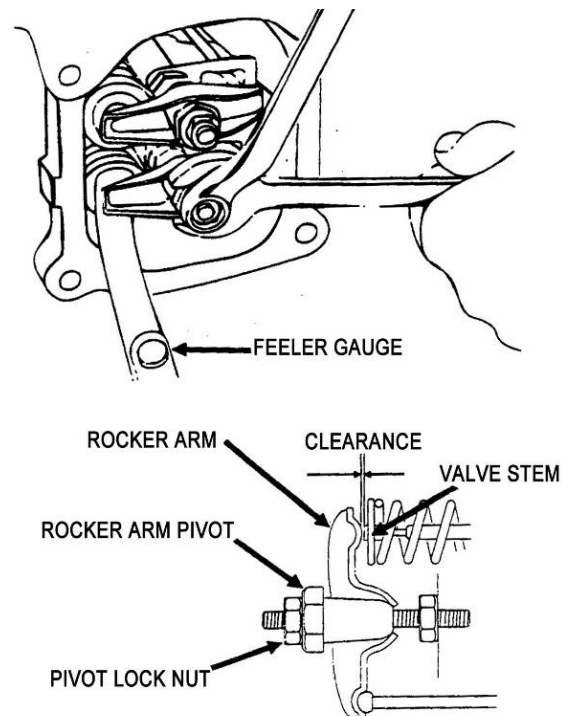

3-6 Adjustment of idle speed

Idle speed

Part III Maintenance

1. Start the engine. And allow the engine to warm to normal operating temperature.
2. With the engine idling, adjust the throttle stop screw to obtain the recommended engine idle speed.

Recommended idle speed: 1800±150 rpm

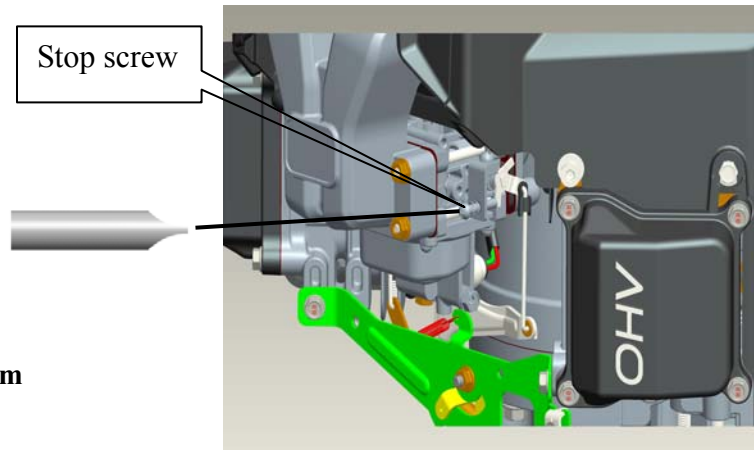

3-7 Adjustment of speed regulator

1. Loosen the governor arm pinch bolt nut, but do not remove it.
2. Move the governor arm anti clockwise to fully open the throttle and hold it in this position.
3. Rotate the governor arm shaft fully anti clockwise and hold it there with a pair of pliers. Tighten the governor arm pinch bolt nut to 11N·m to secure the governor arm to the governor arm shaft.
4. Check to be sure the governor arm and throttle valve move free

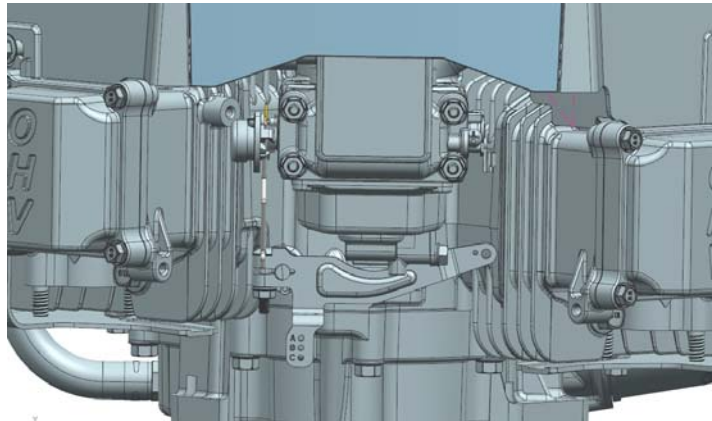

3-8 Electric Starter

First turn the engine switch to the ON position. Then turn the key to the START position, and hold it there until the engine starts.

If the engine fails to start within 5 seconds, release the key, and wait at least 10 seconds before operating the engine starter again.

NOTICE

Using the electric starter for more than 5 seconds at one time will overheat the starter motor and can damage it.

When the engine starts, release the key, allowing it to return to the ON or RUN position.

Because of the large amount of current, never keep the engine switch turned to the start position when the starter motor will not turn over, or the current may burn out the starter motor windings.

Part III Maintenance

3-9 Storage of engine

After it is shut down, cool the engine down for at least half an hour prior to cleaning. Clean the outer surface, repair the damaged baking finish and coat thin rust resisting oil on areas that are possible rust.

Caution

Washing water with high pressure can enter the air filter and silencer and even enter the cylinder along with the air passage and cause corrosion and damage.

Water splashing on the hot engine may wreck damage. Therefore, cleaning must be done after the engine is cooled down.

- 1) Place a suitable container for containing gasoline under the carburetor (under the overflow pipe).
- 2) Loosen the oil drain bolt of carburetor, drain the oil in the carburetor to the container for containing gasoline and fasten the oil drain bolt of carburetor after completing oil drain.

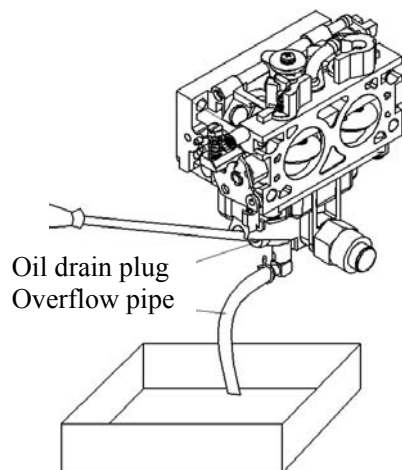

- 3) Replace engine oil when use it again.
- 4) Remove the two spark plugs.
- 5) Pour into a spoon of (5-10 ml) clear engine oil into the cylinder head.
- 6) Rotate the engine for several circles to scatter the engine oil spread throughout the cylinder head.
- 7) Re-install the spark plug.
- 8) Rotate the engine slowly till you feel the resistance. The inlet and exhaust valves are both in the closed status, which prevent moisture entering the cylinder head.
- 9) Cover an anti-dust coating to the engine and place it in a ventilated dry place.

During the storage, charge the battery every month. It is benefit for prolonging the service life of the battery.

Part IV Faults Diagnosis

4-1 Difficulty of engine in starting

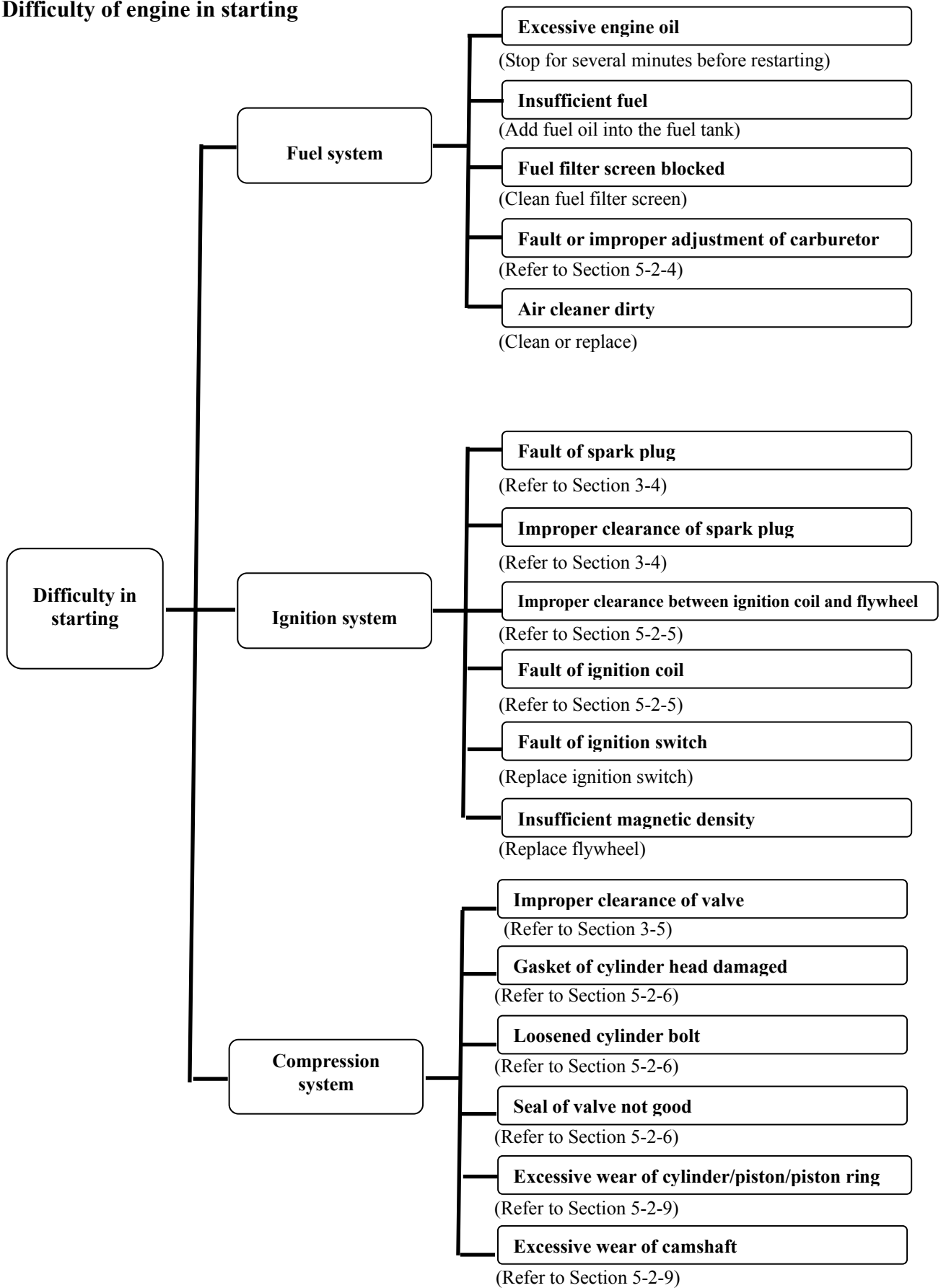

Part IV Faults Diagnosis

4-2 Underpower of engine

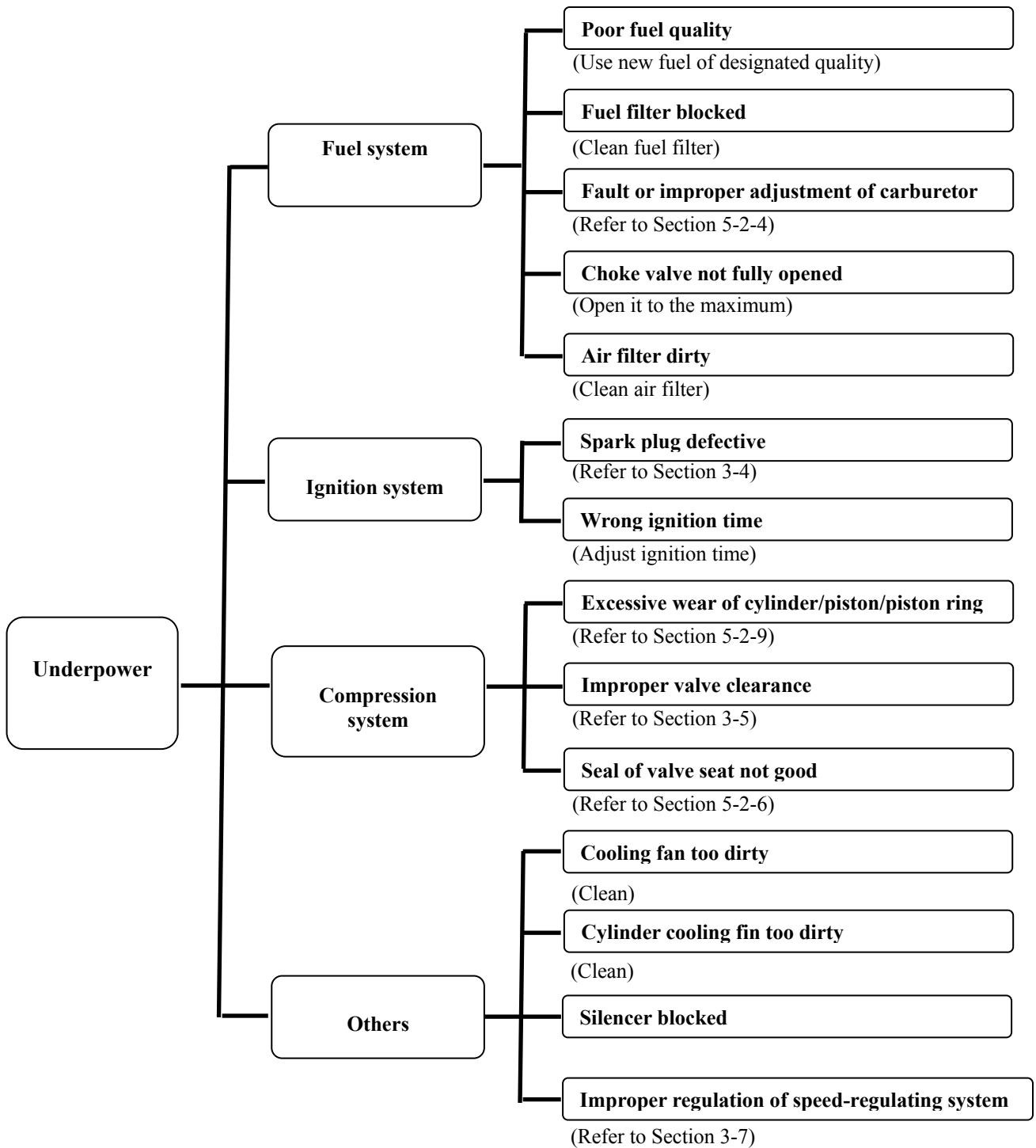

Part IV Faults Diagnosis

4-3 Rotating speed instability of engine

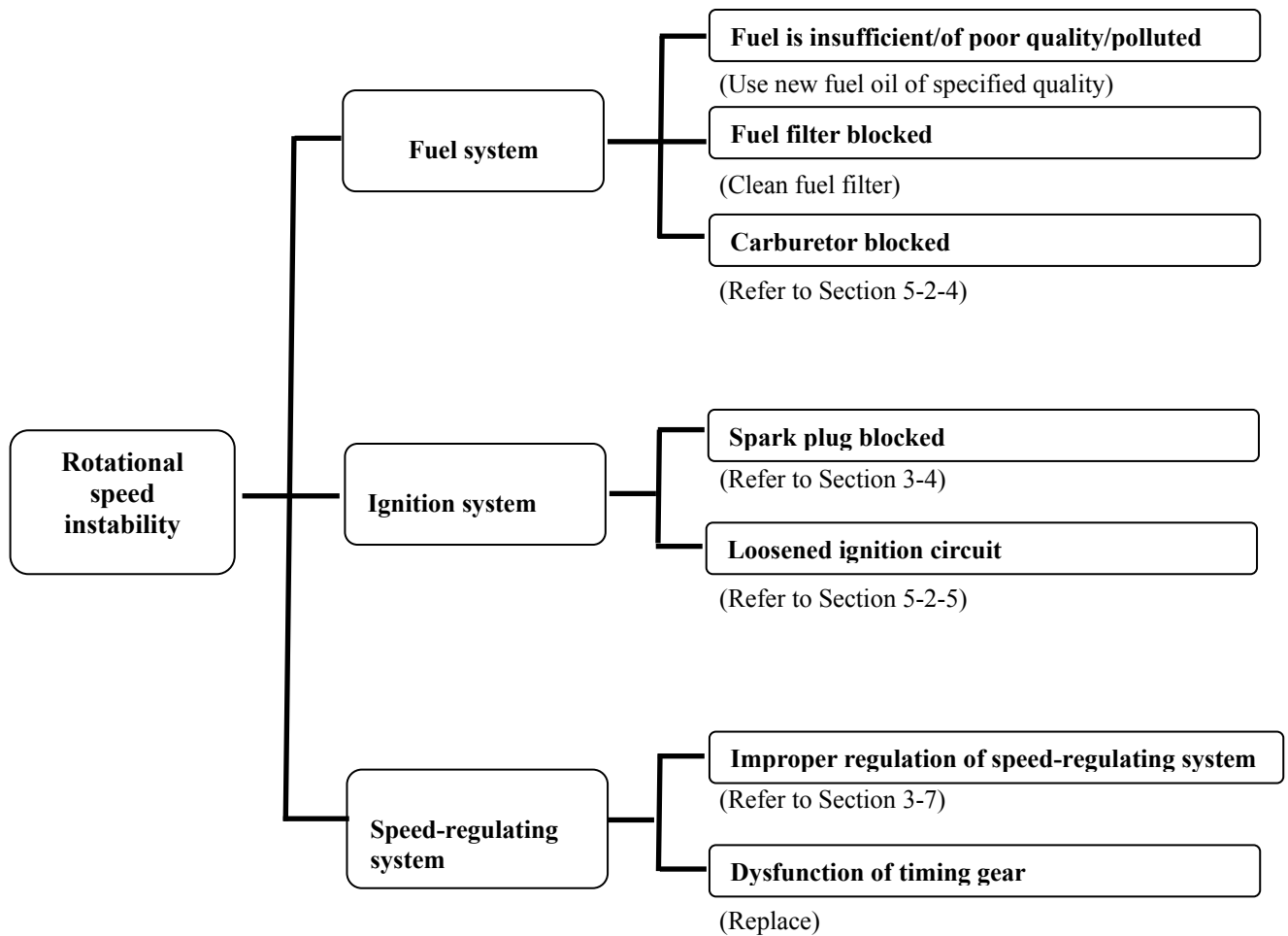

Part IV Faults Diagnosis

4-4 Abnormal exhaust colors of engine

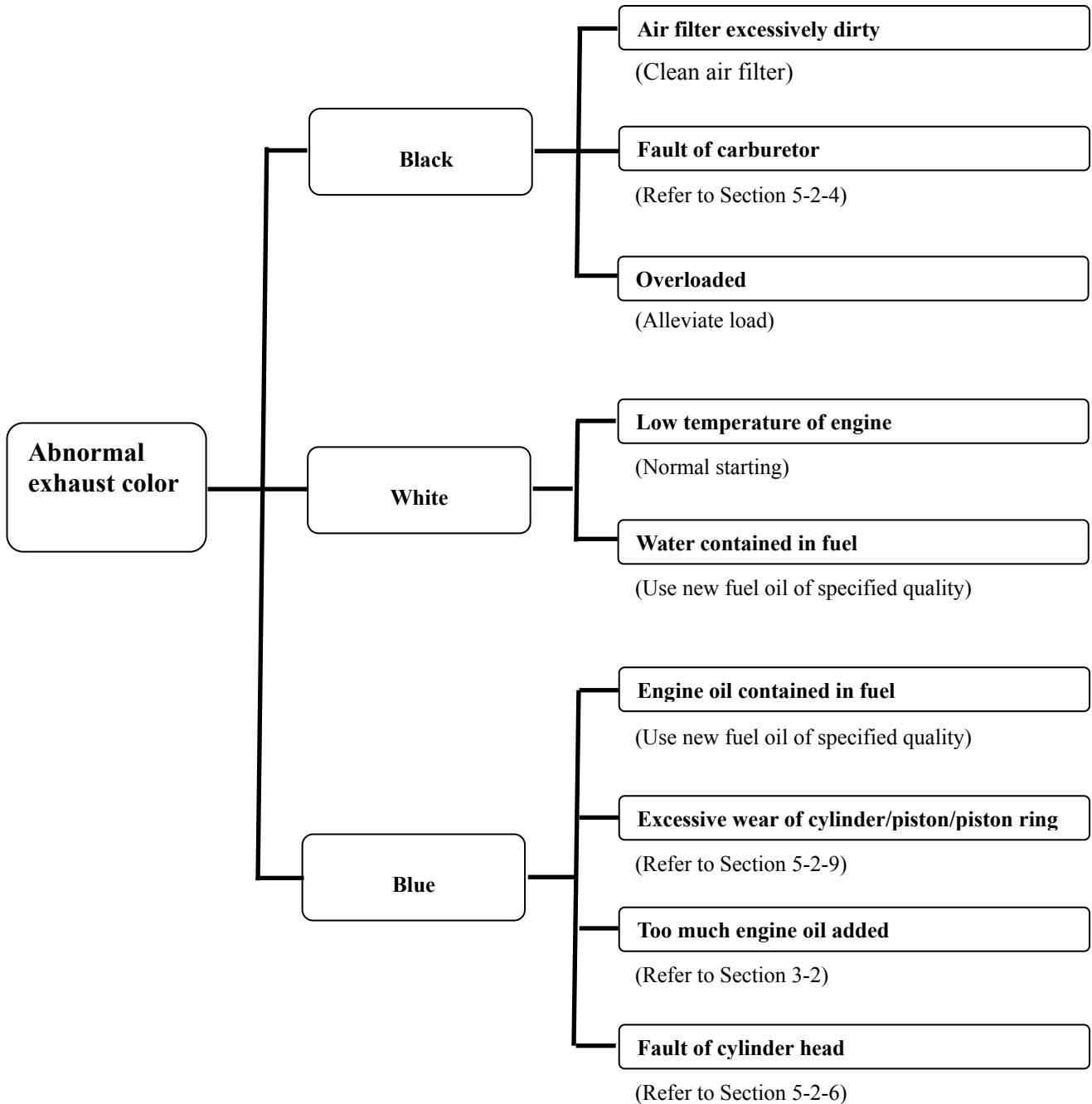

Part IV Faults Diagnosis

4-5 Engine is easily to be flameout

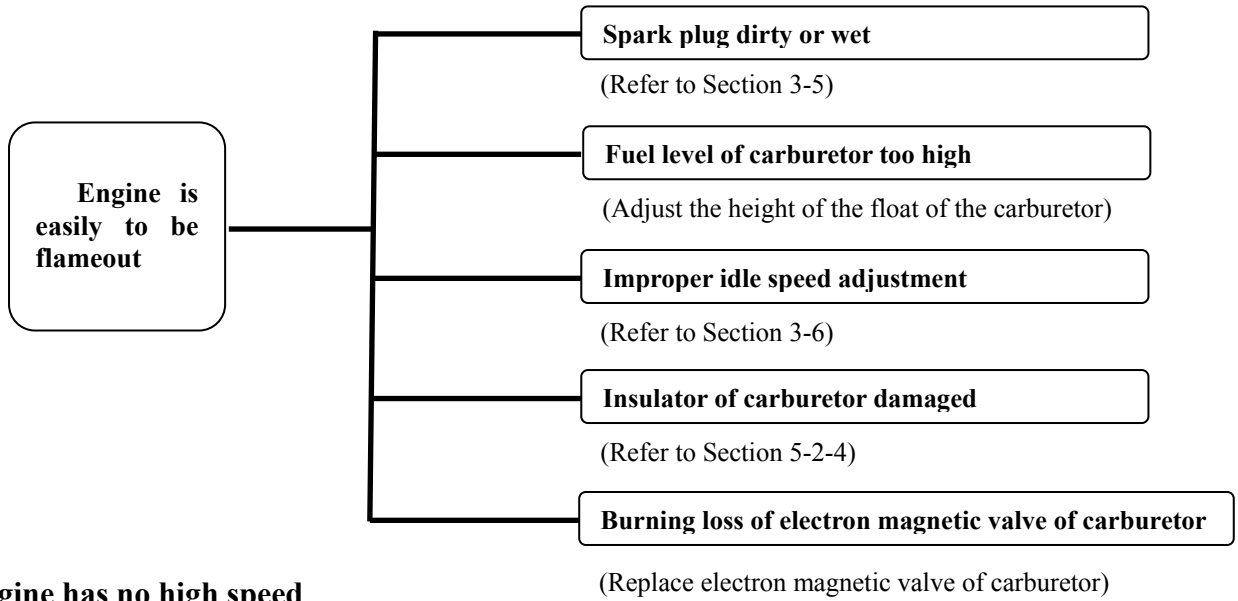

4-6 Engine has no high speed

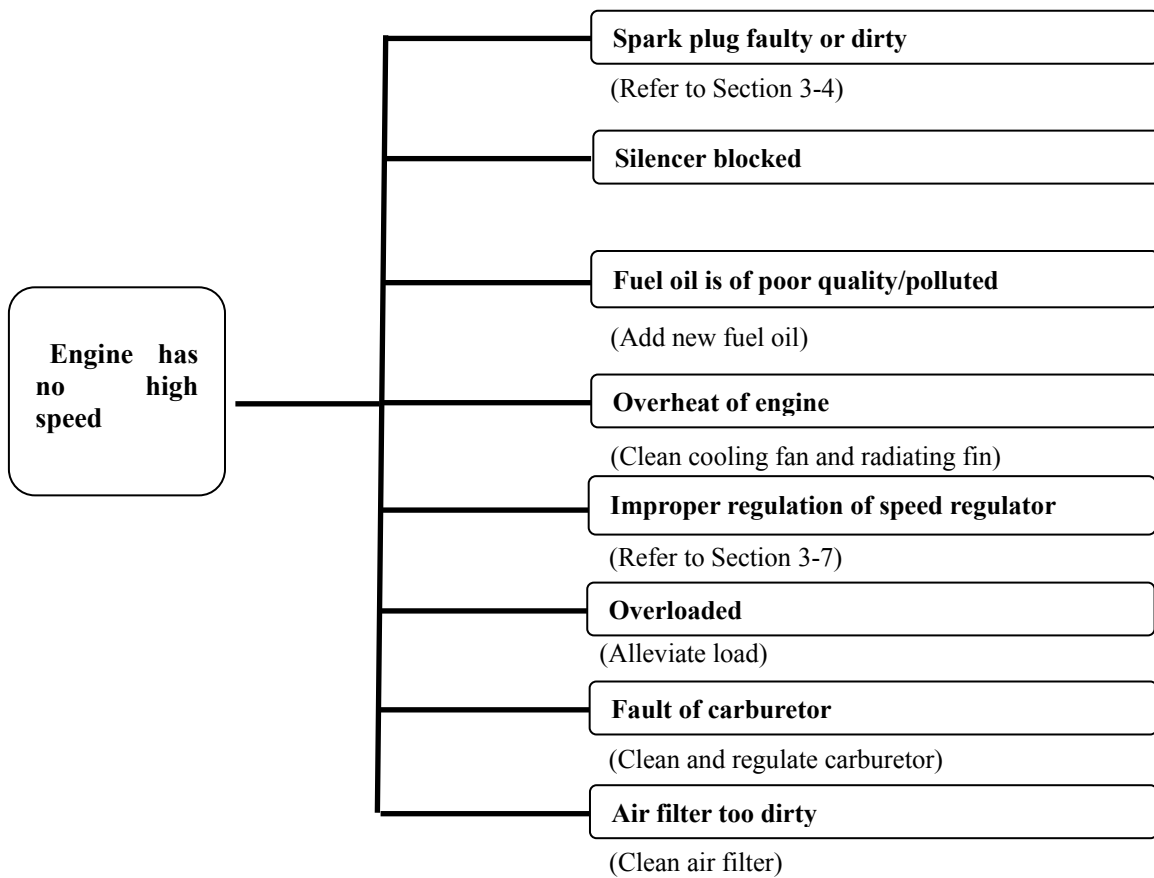

Part IV Faults Diagnosis

4-7 Overheat of engine

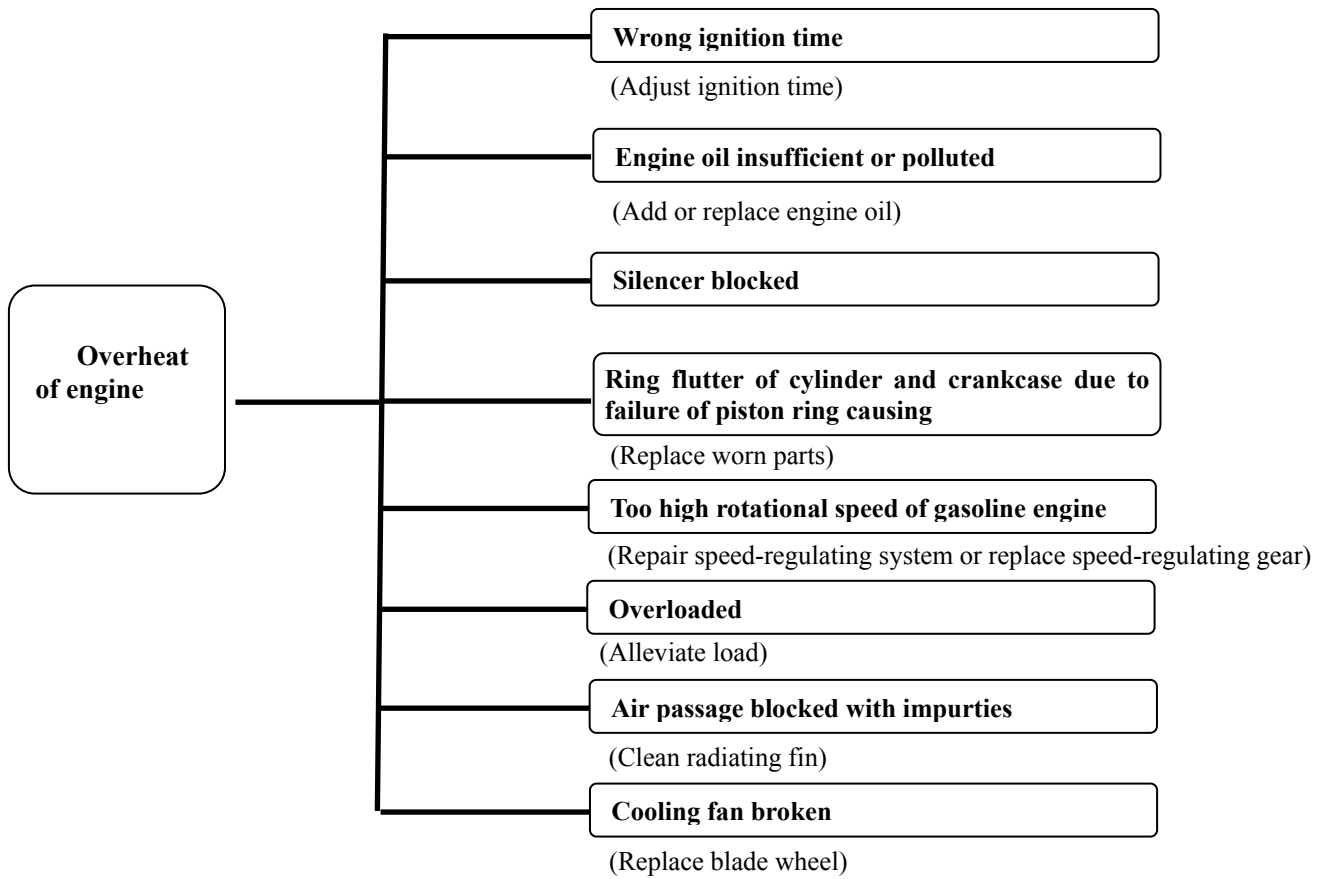

Part IV Faults Diagnosis

4-8 Abnormal noises of engine

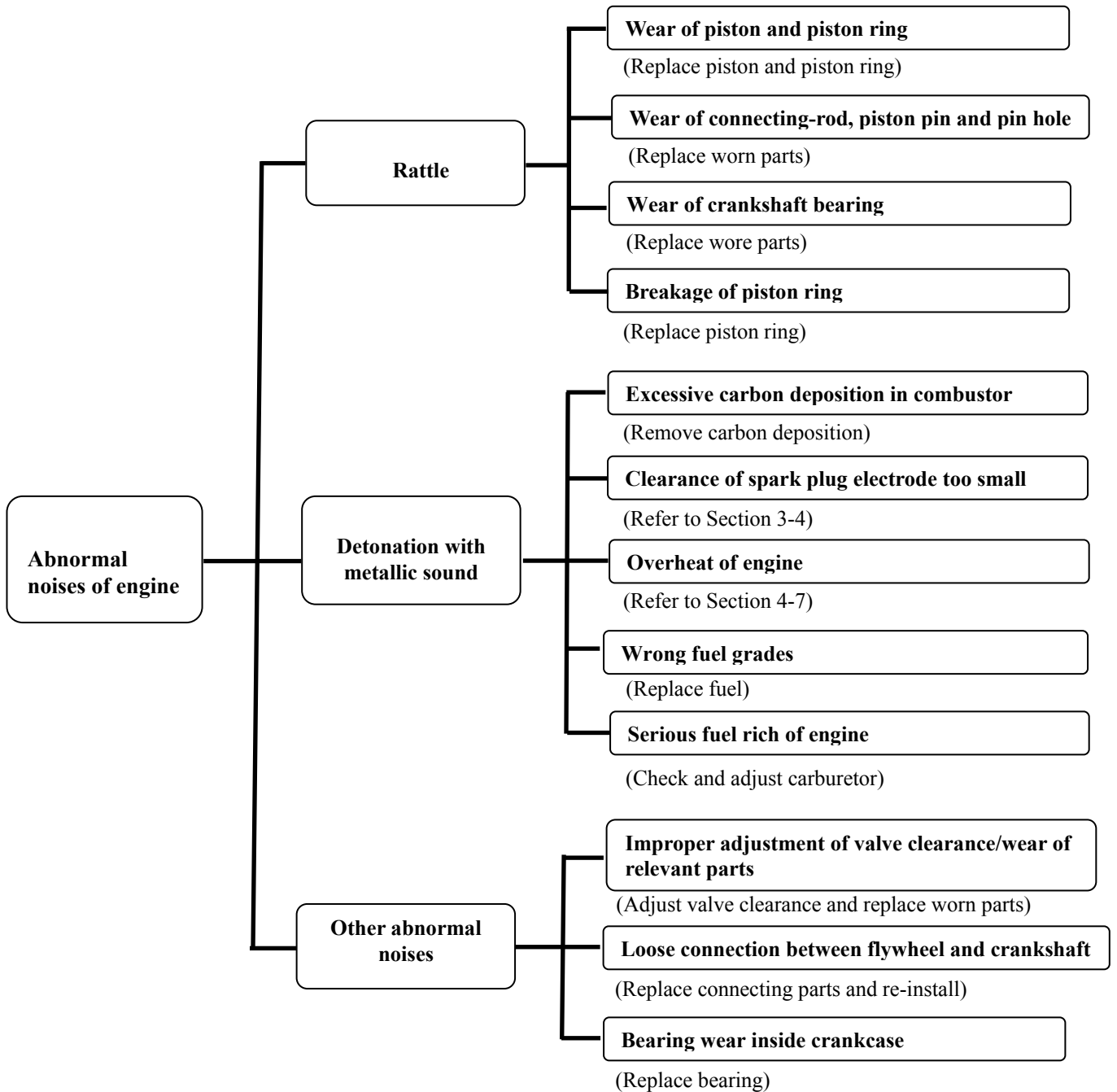

Part IV Faults Diagnosis

4-9 Fault of electric starting system

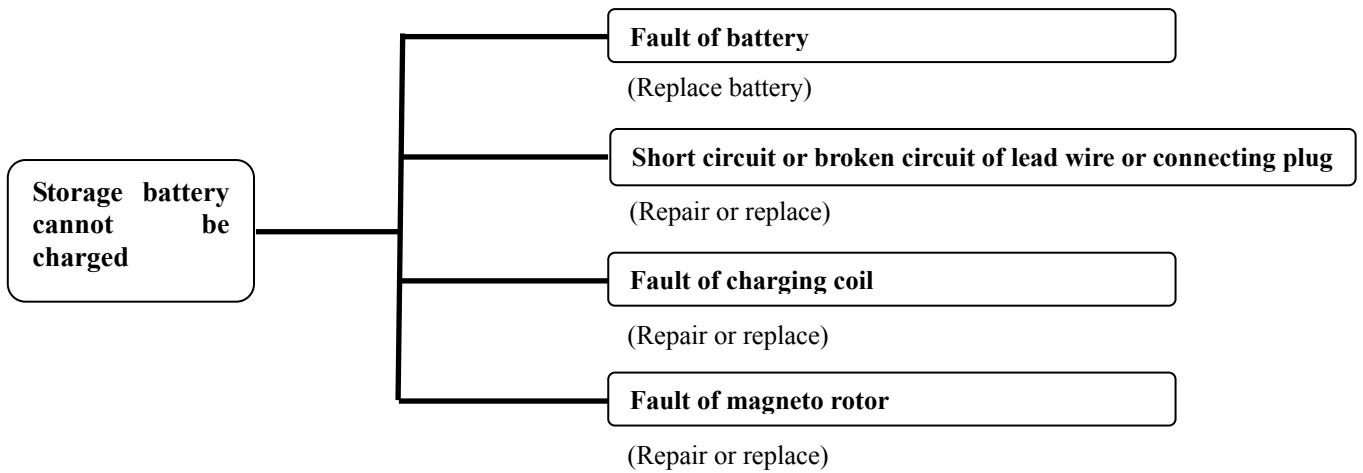
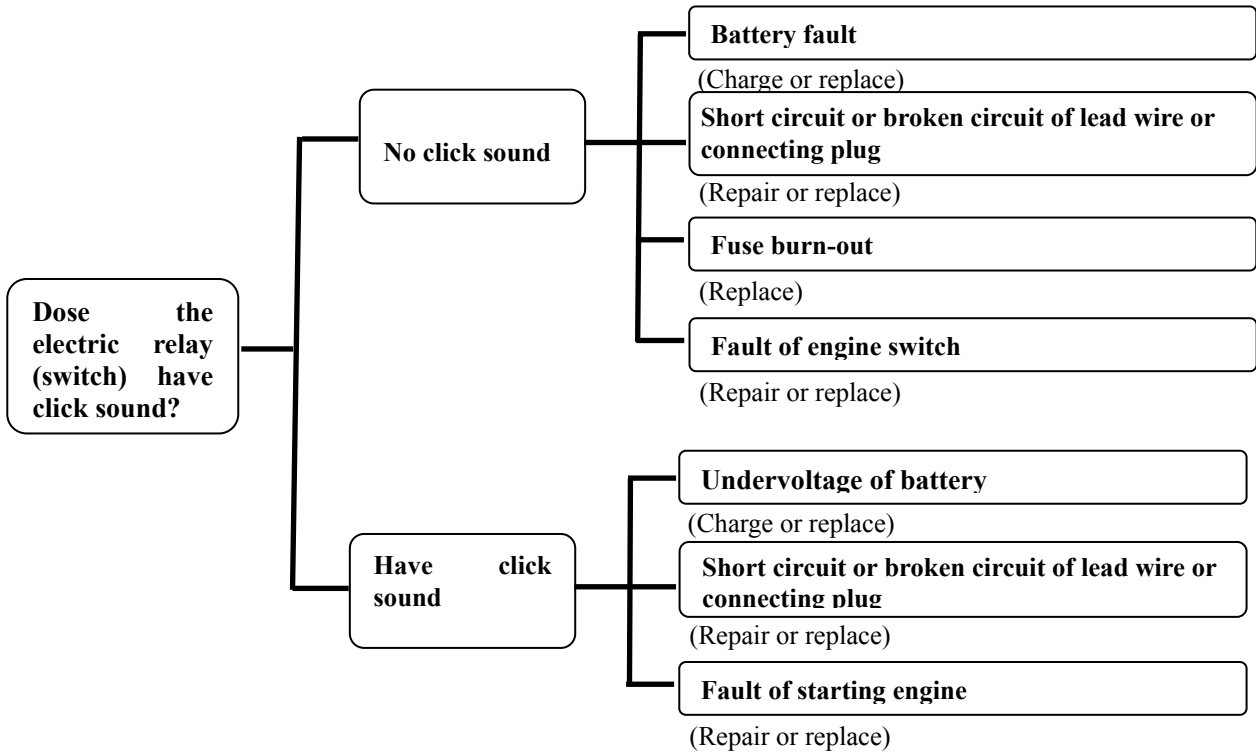

Part IV Faults Diagnosis

4-10 Check the cylinder pressure

- 1) Disassemble spark plug cap and spark plug.
- 2) Assemble pressure meter in the spark plug hole.
- 3) Use starter motor make the engine runing.

Cylinder pressure	Right = 10 ~13 bar Left = 3 bar
-------------------	------------------------------------

NOTE

Speed is faster than 1000r/min, the pressure relief valve does not work, at this time, we can get the operationg cylinder pressure.

At 1400 rpm pressure = 10 to 13 Kgf/cm2

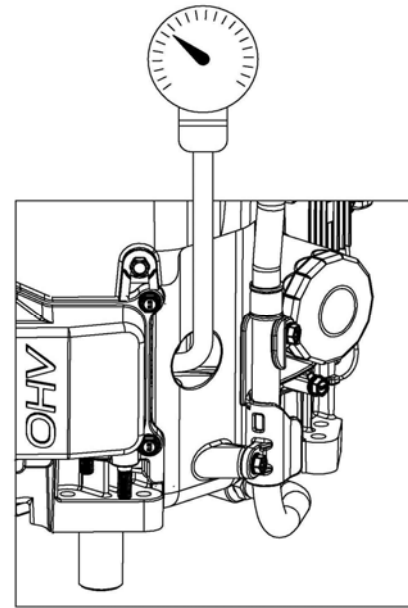

4-11. Checking spark

- 1) Remove spark plug
- 2) Put the spark plug on the spark cap
- 3) Connect (-) electrode of the spark plug (thread) to grounding, pull starter to check if there is spark at the electrode joint.

WARNING

Don't grape spark terminal by wet hand when testing.

If touching the high voltage line by wet hand, pulling starter can produce high voltage electric, being danger.

Sprinkled fuel can cause fire around the spark plug. First, clean the fuel, then check. When checking, keep far away from the spark plug hole.

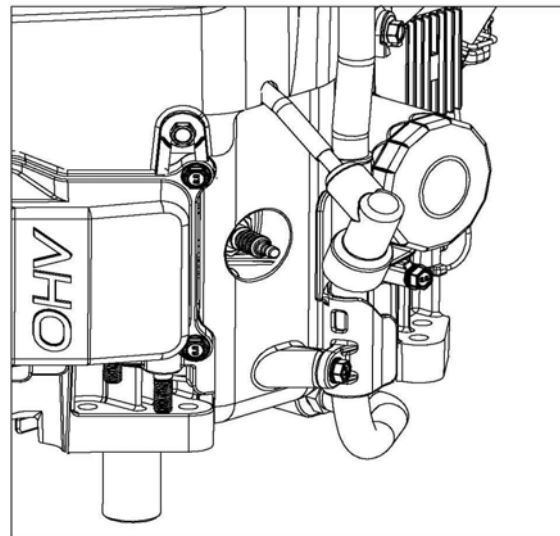

Chapter V Disassembly & Repair

5-1 Precautions on disassembly/assembly

5-1-1 Disassembly

1. Get familiar with the constitution and operating principle of the machine prior to disassembly, which is the precondition for correct disassembly.
2. Not disassemble those without the need. Blind disassembly will not only increase workload of repair but also damage the original good coordinating relation and precision among parts so as to cause new hidden faults.
3. Use proper disassembly tool and adopt the correct disassembly method. It is prohibited to tap strongly during disassembly so as to avoid deformation and damage of parts. To enhance repair efficiency, it prefers to use special disassembly tools.
4. The disassembly must be gradually conducted from the outside to the inside. Generally, the disassembly order is “overall machine, assembly, components and then parts”.
5. To assemble the machine smoothly after repair, the following shall be noted during disassembly:
 - 1) Check and make marks (such as scribing, arrow and text on some parts). For parts without marks, make signs on non-operating sides so as to re-install them correctly.
 - 2) Place parts reasonably and store them in categories. Parts of the same assembly or components shall be stored together. Parts (e.g. gasket) that are easily to be deformed or lost shall be stored separately.

5-1-2 Assembly

1. The assembly site shall be clean.
2. Prepare proper assembly tools and devices.
3. Parts must be cleaned and dusts, soil, metallic debris, carbon deposition, grease stain and other impurities shall be removed from the surface. Clean and blow it with compression air, cleaning agent, etc.
4. As per the opposite order of disassembly, i.e. assemble as per the order of “from inside to outside and from main part to auxiliary part” and “parts, components, assembly, and then overall machine”.
5. Note to check part marks and assembly signs during assembly so as to avoid neglected assembly.
6. When assembling fastening parts, fasten it from center to both sides and diagonal crossing direction to fasten it for several times. Then fasten it in place with torque wrench.
7. Timely replace each sealing gasket during assembly.
8. Conduct the test running for the machine after the overall machine is assembled, adjusted and checked without errors.

Chapter V Disassembly & Repair

5-2 Disassembly and maintenance of engine

5-2-1 Air filter

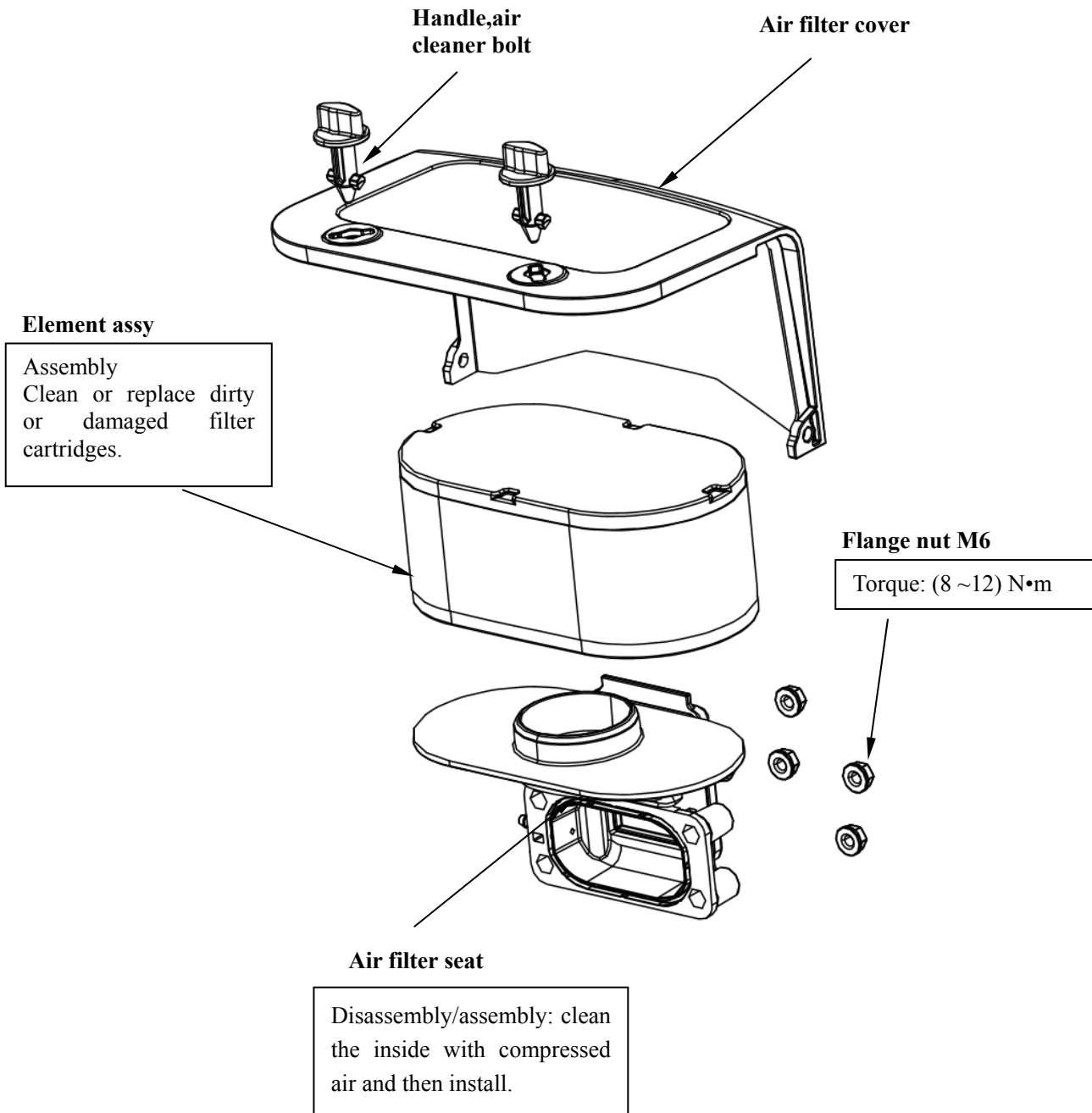

Chapter V Disassembly & Repair

5-2-2 Fan cover

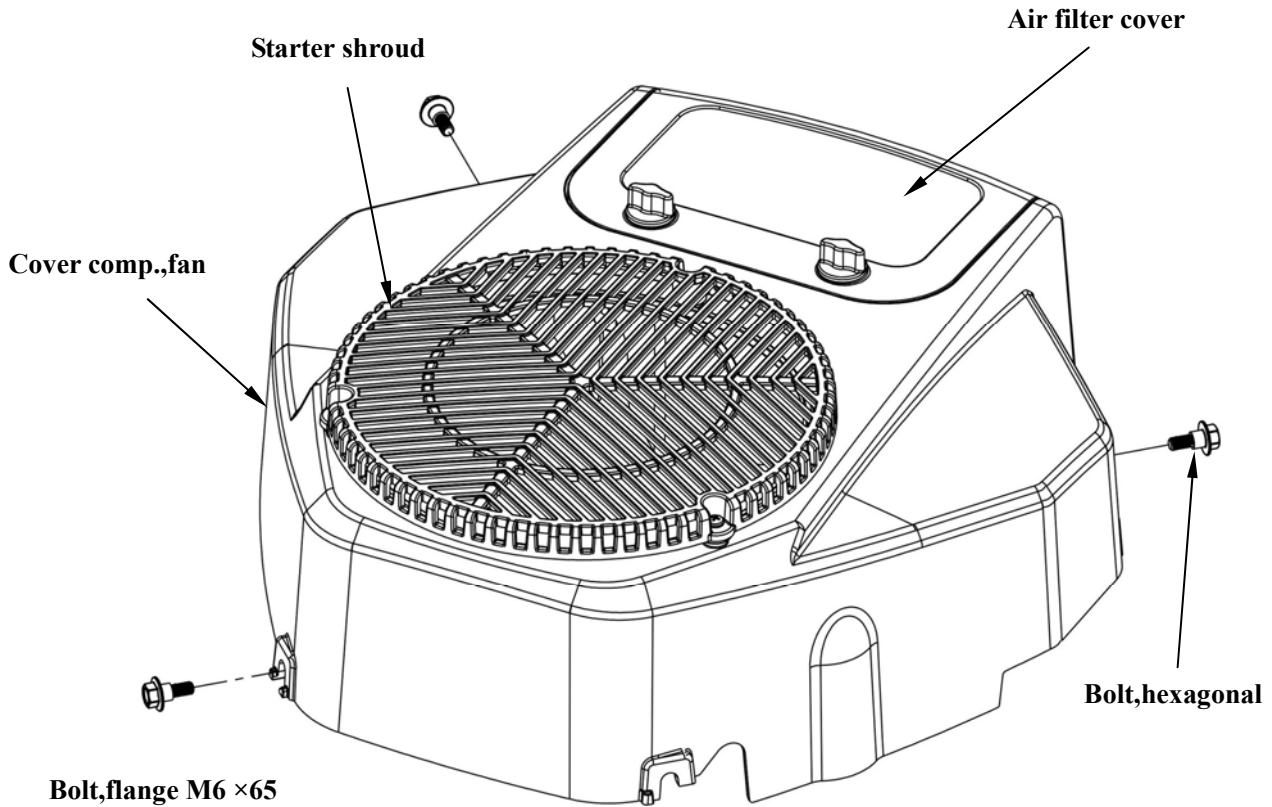

Torque: (8 ~ 12) N•m

Fan, cooling

Assembly:
Align cams at the inner side with the small holes on the flywheel.
Avoid excessive force in disassembly and assembly so as to avoid breaking the blade.

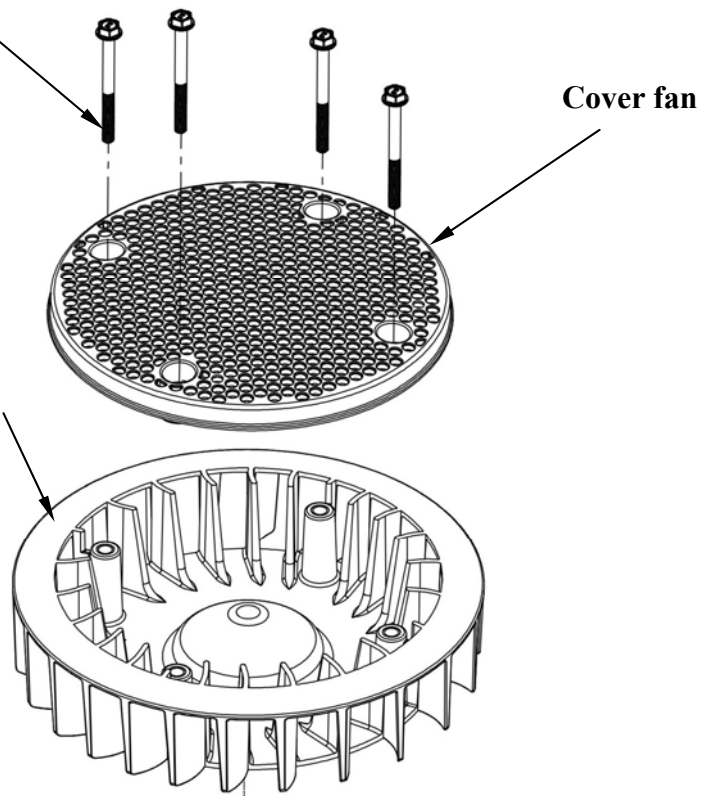

Chapter V Disassembly & Repair

5-2-3 Control level

Throttle return spring

Assembly:
Replace deformed or damaged spring.

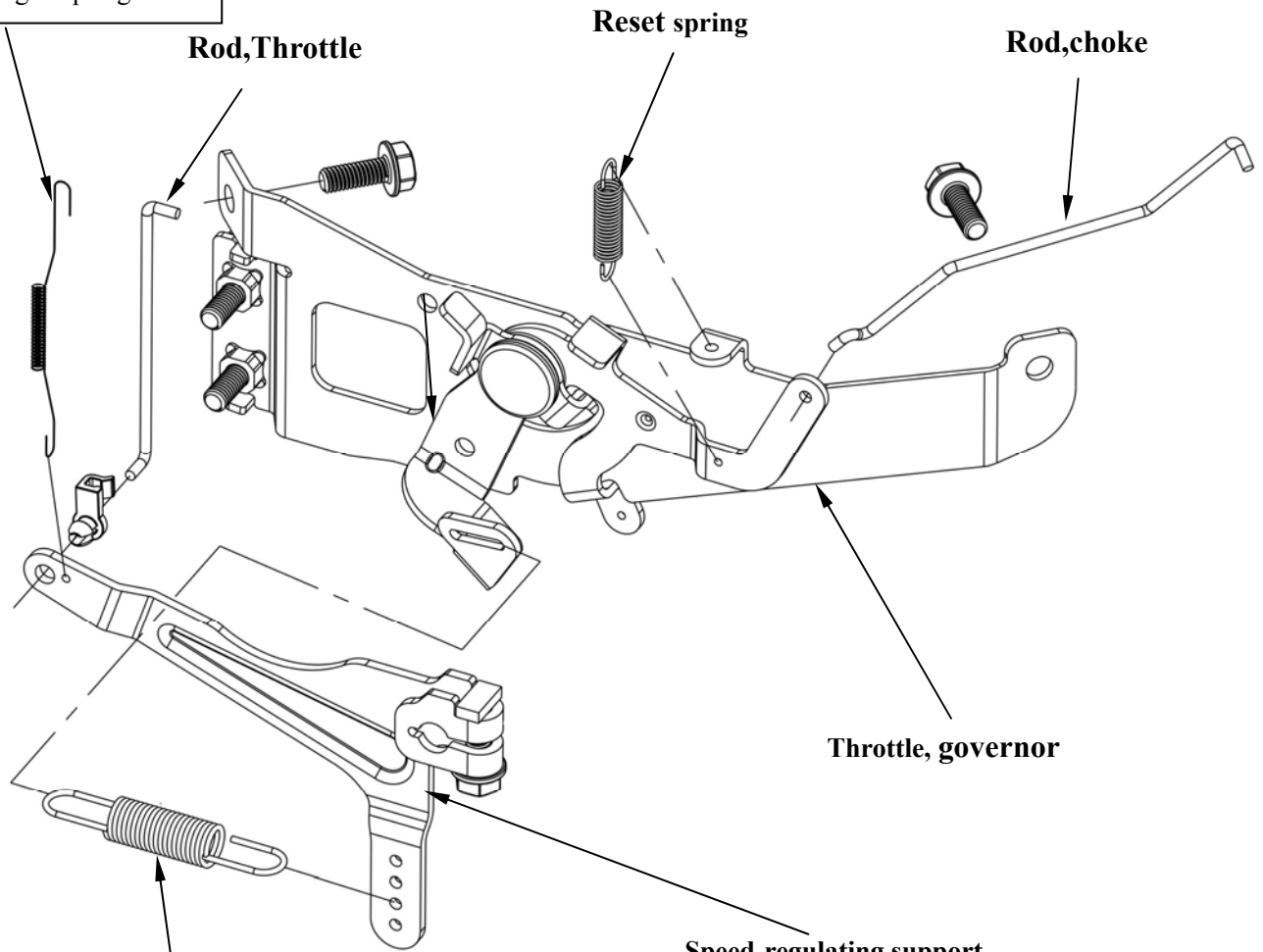

Spring,governor
Assembly:
Replace deformed or damaged spring.

Speed-regulating support
Assembly:
Adjust the speed regulator during assembly.

Chapter V Disassembly & Repair

5-2-4 Carburetor

⚠ Warning

The gasoline is flammable and explosive. The fuel stop valve must be closed before repairing the carburetor and drain the fuel in the carburetor.

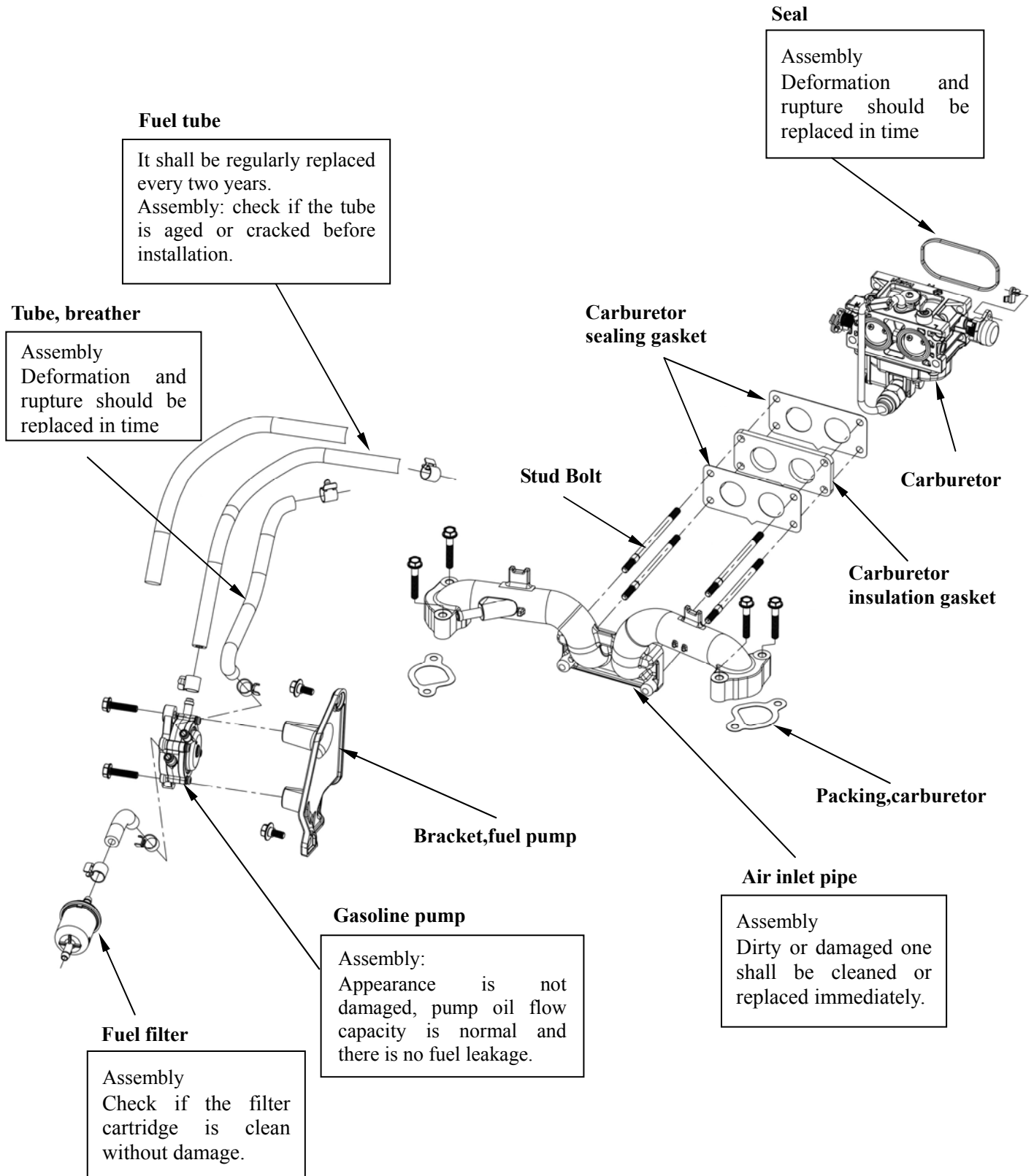

Chapter V Disassembly & Repair

Disassembly/assembly

Note: clean the carburetor prior to installation

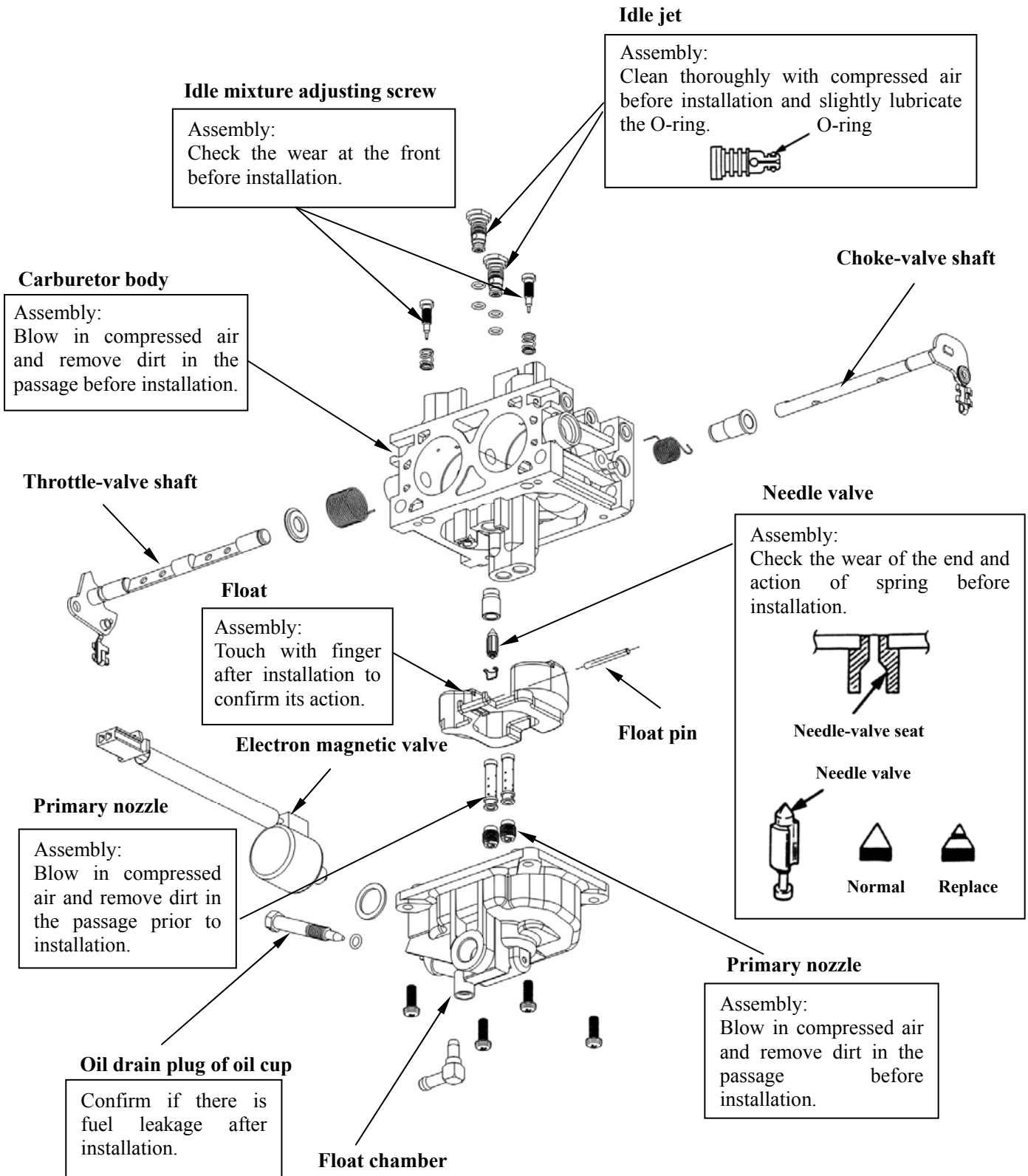

Chapter V Disassembly & Repair

Clean the carburetor

Warning

When using the compression air, to avoid injury, wear protective spectacles or other protective equipment.

Note

Some chemical solvents are of relatively-strong corrosivity and may damage plastic parts such as the O-ring and float. Please carefully read the Solvents Manual. Should you not confirm, don't use the solvent to clean the carburetor. The compression air of high pressure may also damage the carburetor. Please remove the dirt in the passage or pipe mouth with compression air of proper pressure.

- 1) Clean the carburetor with cleanser.
- 2) Blow in the compression air to remove dirt in idle air jet, idle jet, air jet, main jet, main nozzle, etc. prior to installation.

Chapter V Disassembly & Repair

5-2-5 Flywheel and ignition coil a. Disassembly/assembly

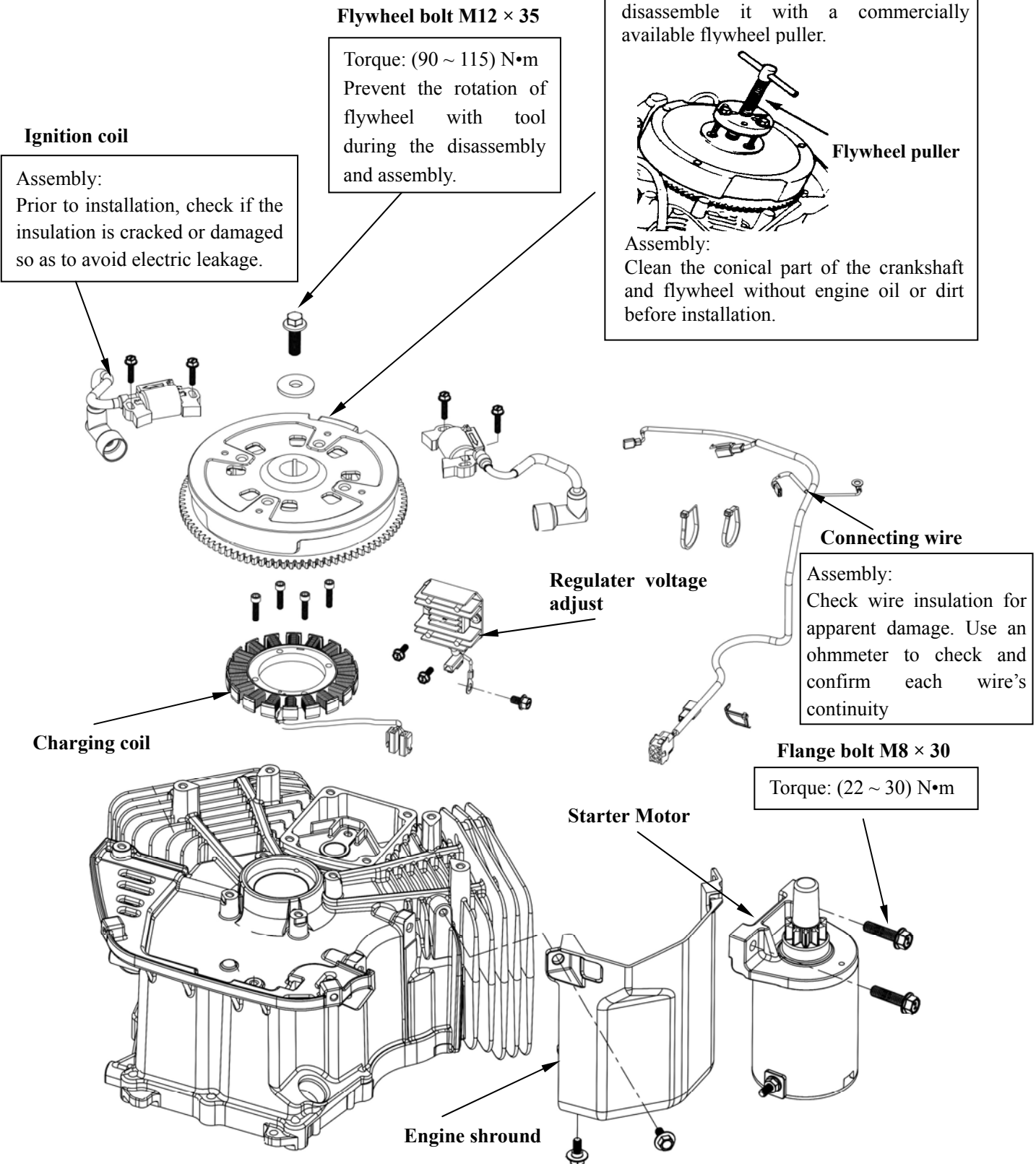

Chapter V Disassembly & Repair

b. Adjustment of clearance between ignition coils

When reassembling igniting coil, adjust the igniting coil gap.

- 1) Lightly tighten the igniting coil mounting bolt.
- 2) Insert the feeler gauge or a piece of paper of the same thickness between the flywheel and coil as shown.
- 3) Push the coil against the flywheel by hand and tighten the two bolts.

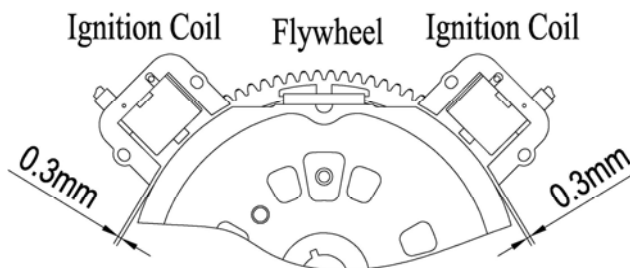

NOTICE

- a) *Adjust both ends of the coil to the same gap.*
- b) *Avoid the magnet portion of the flywheel when adjusting.*
- c) *Inspection*

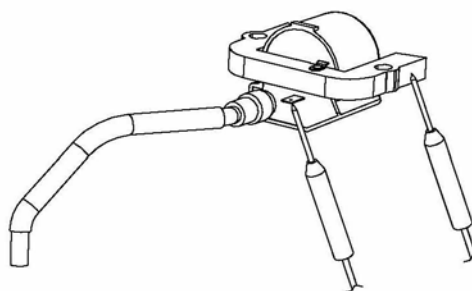

Igniting coil :

<Primary coil>

Put the tester terminal and lead terminal to contact with iron core of coil, and measure the primary coil resistance.

Primary coil resistance	0.95±20% Ω
-------------------------	------------

<Secondary coil>

Put the tester terminal and removed spark plug cap's high tension cord to contact with iron cord and measure the secondary coil resistance.

Secondary coil resistance	9.7±15% KΩ
---------------------------	------------

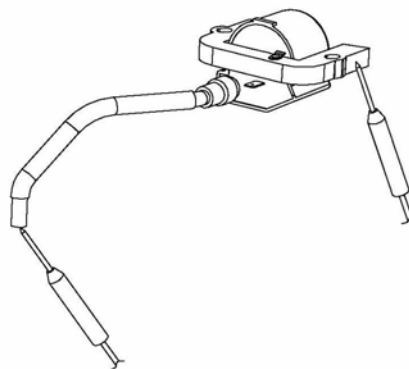

Adjustment

Adjustment is required only when the ignition coil or the flywheel has been removed.

1. Loosen the ignition coil mounting bolts.
2. Insert the thickness gauge or a piece of paper of the proper thickness between the ignition coil and the flywheel, both gaps should be adjusted simultaneously. Avoid the magnet when adjusting the air gap.
3. Push the ignition coil firmly toward the flywheel and tighten the mounting bolts.

Specified clearance	0.3~0.4mm
---------------------	-----------

Chapter V Disassembly & Repair

Charging System

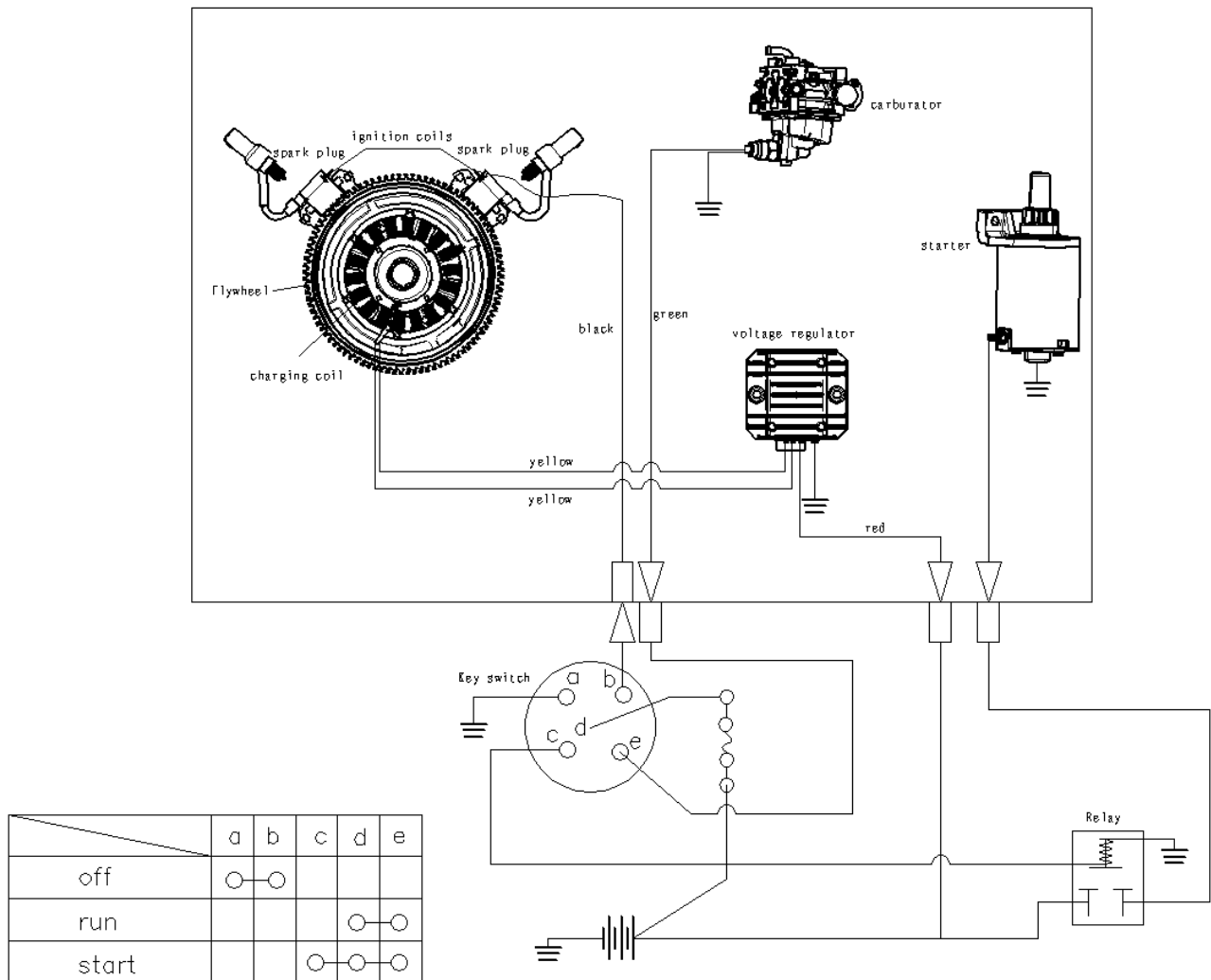

Charging System Operational Inspection

1. Check battery condition.
2. Always check battery condition before condemning other parts of the charging system. The battery must be fully charged in order to conduct accurate charging system tests.
3. Warm up the engine to bring the components up to their normal operating temperatures.
4. Measure regulated output voltage at various engine speeds. Connect a voltmeter across the battery terminals.
5. The readings should show nearly battery voltage when the engine speed is low, and as the engine speed rises, the readings should also rise. But they must stay within the specified range.
6. If the output voltage is much higher than the specification, the regulator is defective, or the regulator leads are loose or open. If the output voltage does not rise as the engine speed increases, the regulator is defective or the alternator output is insufficient for the loads.
7. Regulated Output Voltage Battery Voltage to 14 VDC

Charging Stator Check

1. When the engine is running, the multimeter is placed in the AC file to check whether the output terminal of the charging coil is output or not. If there is no output, please replace the charging coil.

Chapter V Disassembly & Repair

3000r/min, Load with 8Ω , $I \geq 8.0A$;

Charging coil resistance: $0.23 \pm 10\% \Omega$

2. In the case of detecting the output of the charging coil, check the voltage of the battery (generally in 12v~ 12.4V), start the engine, the multimeter is placed in the dc file, and then the voltage of the battery, If the voltage is less than 13V, please replace the pressure rectifier.

Regulator Check

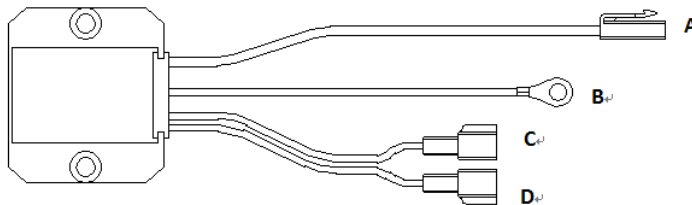

Switch the multimeter to diode: The red pen connects C and D respectively, The black pen by A, Diode forming characteristic, The pressure drop value is $0.5V \pm 10\%$; The red pen is connected with B, and the black pen is connected with C and D respectively, without pressure drop; B short connect with the housing, pressure drop value is 0.

Multimeter to 200 k Ω resistance: Red pen for A, black pen for B, resistance (10 ± 5) M Ω ; Red pen for B, black pen for A, resistance $> 10M\Omega$

NOTICE

1. There are a number of important precautions that are musts when servicing electrical systems. Learn and observe all the rules below.
2. Do not reverse the battery lead connections. This will burn out the diodes in the electrical parts.
3. Always check battery condition before condemning other parts of an electrical system. A fully charged battery is a must for conducting accurate electrical system tests.
4. The electrical parts should never be struck sharply, as with a hammer, or allowed to fall on a hard surface. Such a shock to the parts can damage them.
5. To prevent damage to electrical parts, do not disconnect the battery leads or any other electrical connections when the engine switch is on, or while the engine is running.
6. Take care not to short the leads that the directly connected to the battery positive (+) terminal to the chassis ground.
7. Troubles may involve one or in some cases all items. Never replace a defective part without determining what CAUSED the failure. If the failure was brought on by some other item or items, they too must be repaired or replaced, or the replacement part will soon fail again.
8. Make sure all connectors in the circuit are clean and tight, and examine wires for signs of burning, fraying, etc. Poor wires and bad connections will affect electrical system operation.
9. Measure coil and winding resistance when the part is cold (at room temperature).

Chapter V Disassembly & Repair

5-2-6 Cylinder head and valve

Disassembly/assembly

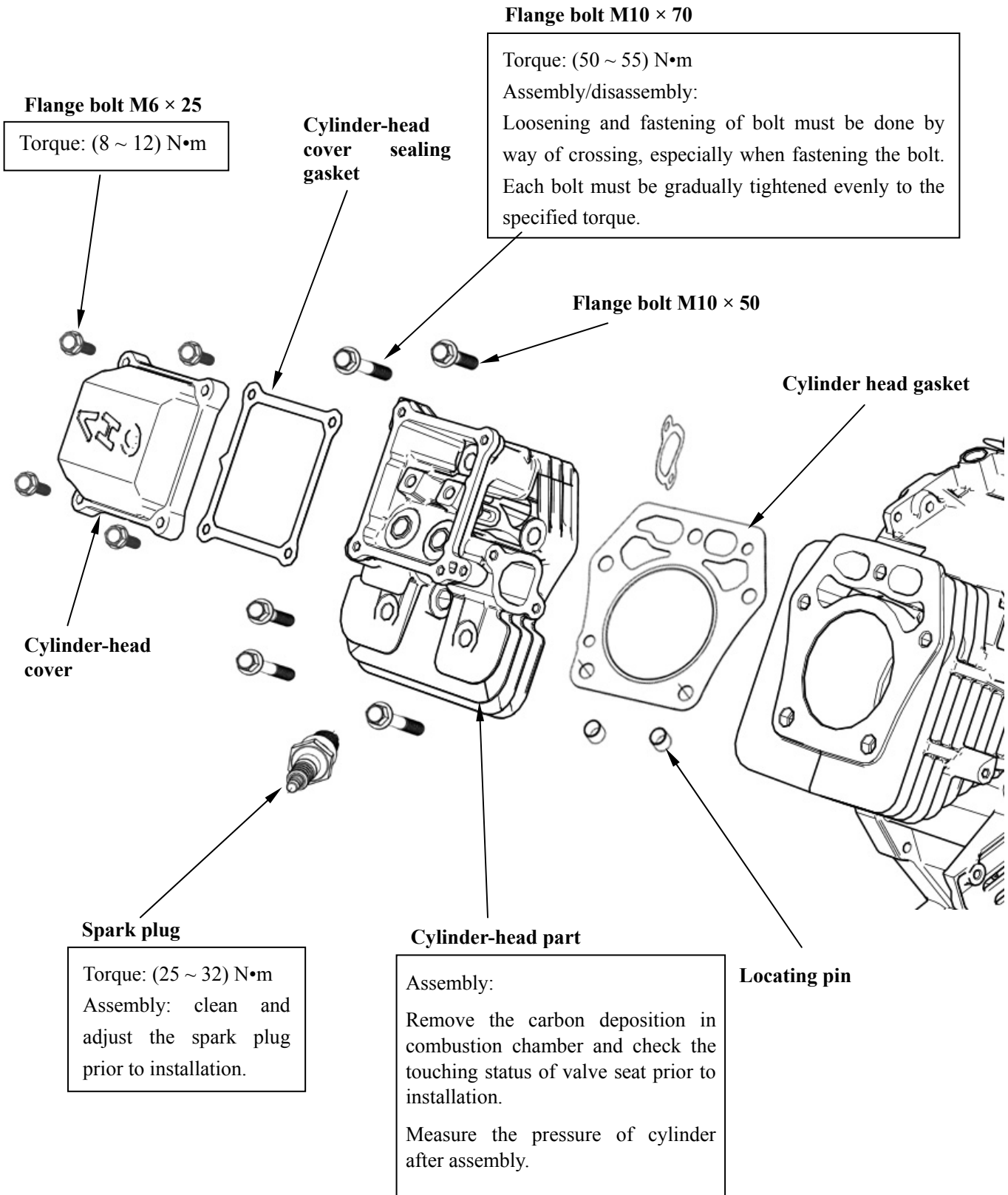

Chapter V Disassembly & Repair

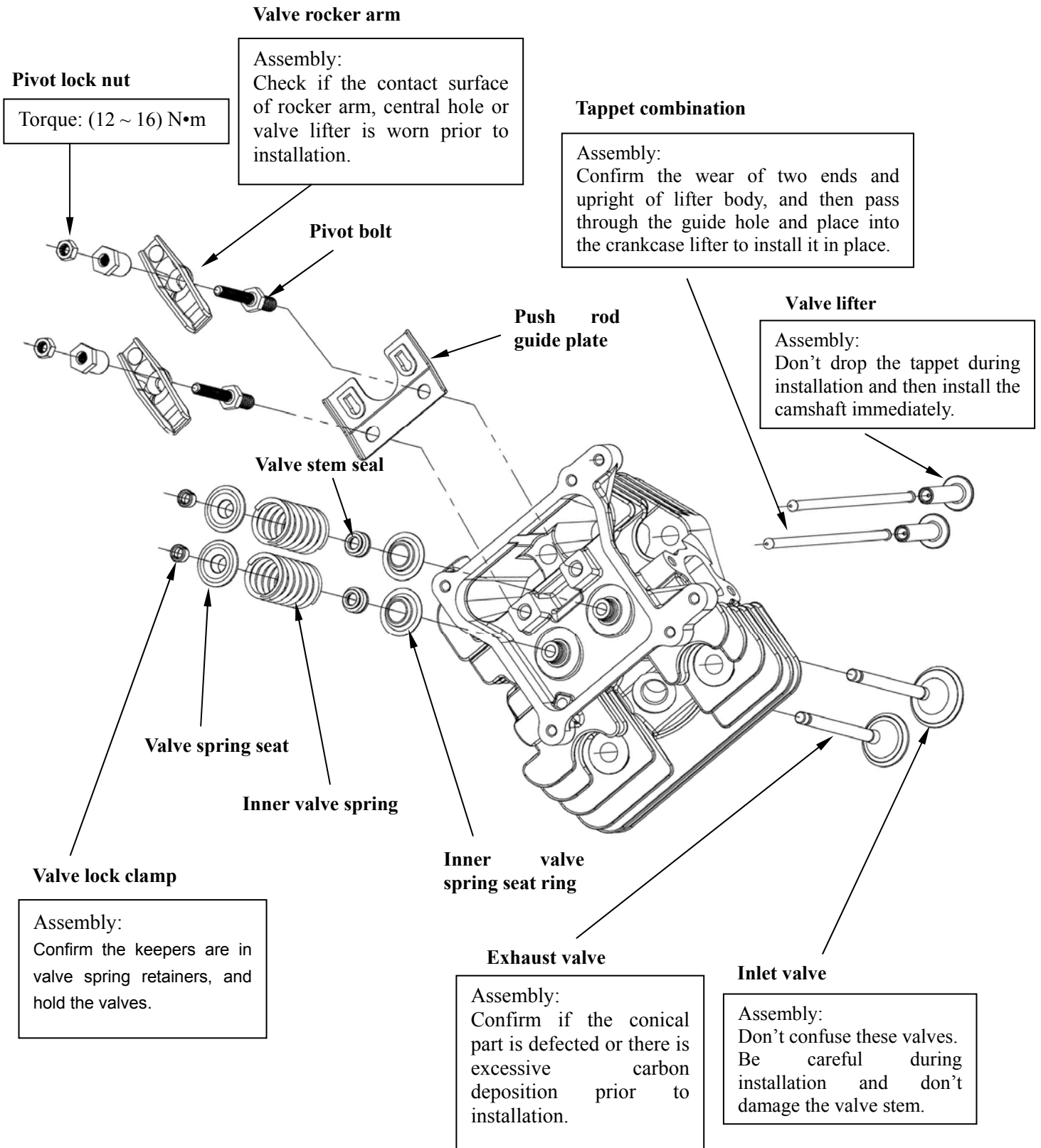

Chapter V Disassembly & Repair

Free length of the valve spring

Measure the free length of valve spring.

Standard	Maintenance Limit
39.5mm~40.5 mm	39mm

Replace the spring if the maintenance limit is exceeded.

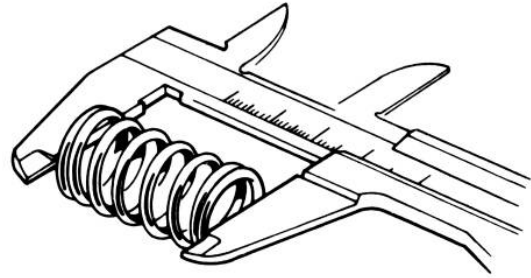

Width of valve seat

Remove the carbon deposition in combustor and check if the valve seat has corrosion or damage.

Measure the width of valve seat.

Standard	Maintenance Limit
0.7mm~0.8 mm	1.3 mm

If the width of valve seat is less than the standard value or exceeds the maintenance limit, trim the valve seat once.

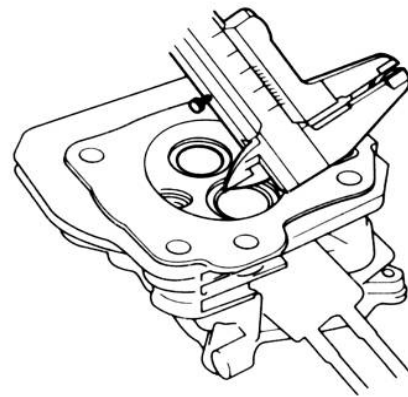

Cylinder head

1. Remove the carbon deposition in combustor and residues of gasket attached onto the cylinder head.
2. Check if there is any crack at the spark plug hole, valve seat surface and valve pipe.
3. Check if there is deformation of cylinder head with straightedge or thickness gauge as shown in the figure.

Maintenance Limit	0.05mm
-------------------	--------

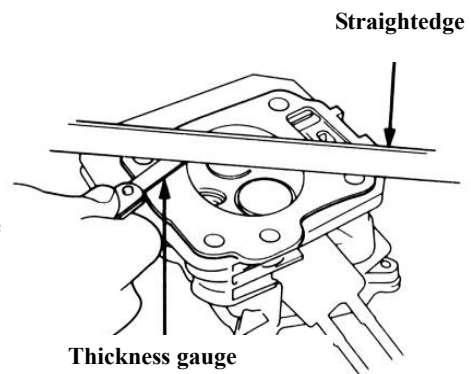

Outer diameter of valve stem

Check each conical side of the valve to see if there is any uneven, curved or abnormal wear of valve stem.

Replace the valve if necessary. Measure and record the outer diameter of each valve stem.

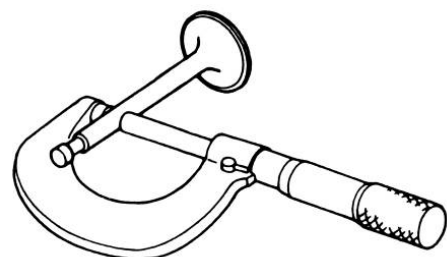

Chapter V Disassembly & Repair

	Standard	Maintenance Limit
Inlet valve	6.565-6.58 mm	6.515 mm
Exhaust valve	6.545-6.56 mm	6.495 mm

Replace the valve if the outer diameter of valve stem is less than the maintenance limit.

Inner diameter of valve guide

Remove the carbon deposition in the exhaust valve pipe with reamer prior to measurement.

Measure and record the inner diameter of each valve guide.

Standard	Maintenance Limit
6.6-6.615 mm	6.665 mm

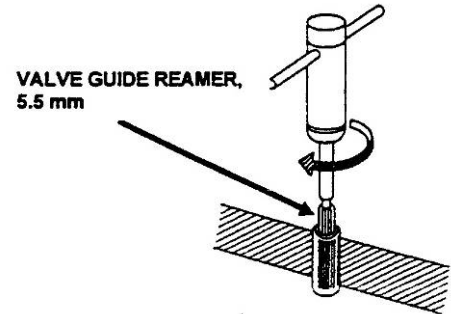

Clearance between valve guide and valve stem

Deduct the outer diameter of valve from the corresponding inner diameter of valve guide.

Obtain the clearance between the valve guide and valve stem.

	Standard	Maintenance Limit
Inlet valve	0.02 ~ 0.05 mm	0.15 mm
Exhaust valve	0.04 ~ 0.07 mm	0.17 mm

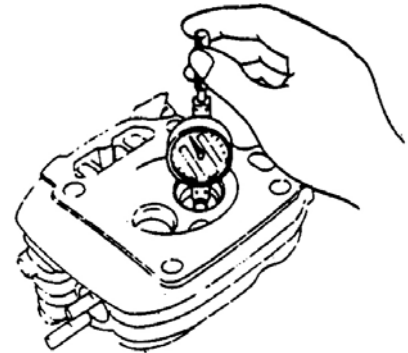

If the clearance value between the valve stem and guide exceeds the maintenance limit, judge if replacing a new guide of standard dimension will make the clearance achieve within the maintenance limit; if yes, replace the valve guide (or cylinder head) as required and ream the valve guide to make it a better coordination. If the clearance between the valve stem and new valve guide still exceeds the maintenance limit, replace the valve too. Trim the valve seat again when replacing the valve guide.

Trim the valve seat

1. Thoroughly remove the carbon deposition in the combustor and on the valve seat.

2. Coat a thin layer of blue lead power on the surface of the valve or ink of marking pen which is easily to be erased.

3. Insert into the valve and press it for several times to make it tightly close to the valve seat. Assure not to rotate the valve on the valve seat. Coating on the valve seat will show the de-concentric feature of valve or valve

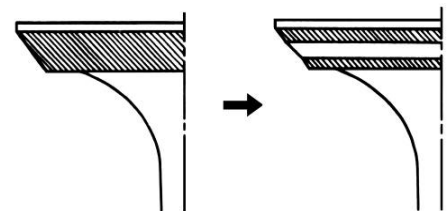

Chapter V Disassembly & Repair

seat.

- Grind the valve seat with a 45° grinder to make the valve seat smooth and concentric; operate as per the manual of valve seat grinder provided by the manufacturer.

Rotate the grinder clockwise and the anticlockwise rotation is not allowed.

Lift the valve seat grinder from the valve seat and continue grinding.

- Shorten and adjust the valve seat a 30°-32° and 60° grinders,
 Make the valve seat connect with the central part of the valve surface.
 Grind the top edge of the valve seat with a 30°-32° grinder.
 Grind the bottom edge of the valve seat with a 60° grinder.
 Assure the contact width of valve seat after completion is within the specified scope.

High contact surface

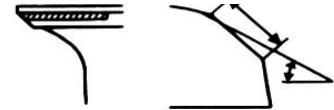

Low contact surface



Width of valve seat

Standard	Maintenance Limit
0.7 mm~0.8mm	1.3 mm

- Slightly grind with the 45° grinder to remove any burr at the edge of valve seat.
 - After trim the valve seat again, check that after the valve is put in, if it contacts evenly.
 - Coat a thin layer of blue crocus on the surface of the valve or ink of marking pen which is easily to be erased.
 - Insert into the valve and press it for several times to make it tightly close to the valve seat. Assure not to rotate the valve on the valve seat.
- If colorant is evenly coated on the conical side of the valve seat as shown in the figure, it indicates that the contact between valve and valve seat is good.

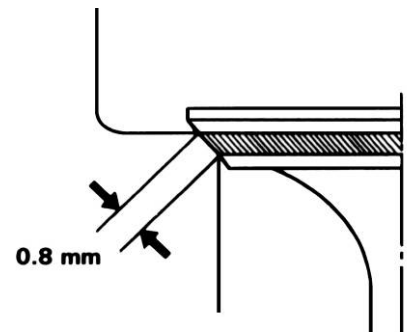

Note:

To avoid severe engine damages, thoroughly remove the abradant on the cylinder head prior to assembly.

- Check the valve clearance after assembly.

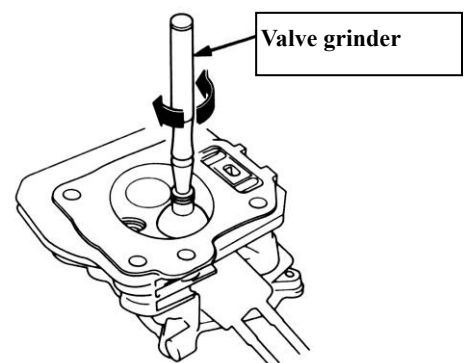

Chapter V Disassembly & Repair

5-2-7 Speed-regulating arm, breather slot

Disassembly/assembly



Oil seal 35 × 52 × 7 mm

Assembly: don't curl the edge of oil seal when passing through the crankshaft.

Tube, breather

Assembly
Deformation and rupture should be replaced in time

Breather-slot cover plate

Breather-slot sealing gasket

Filter screen

Assembly: edge of the filter screen is not exposed and the dirty ones are required to be cleaned timely.

Valve, chamber

Assembly: adjust or replace deformed or non-completely-sealed valves.

Air guide sleeve

Oil seal

Pin lock

Assembly:
Immediately fit the split pin after assembling

Speed-regulating arm

Assembly:
Confirm if the action is smooth after installation.

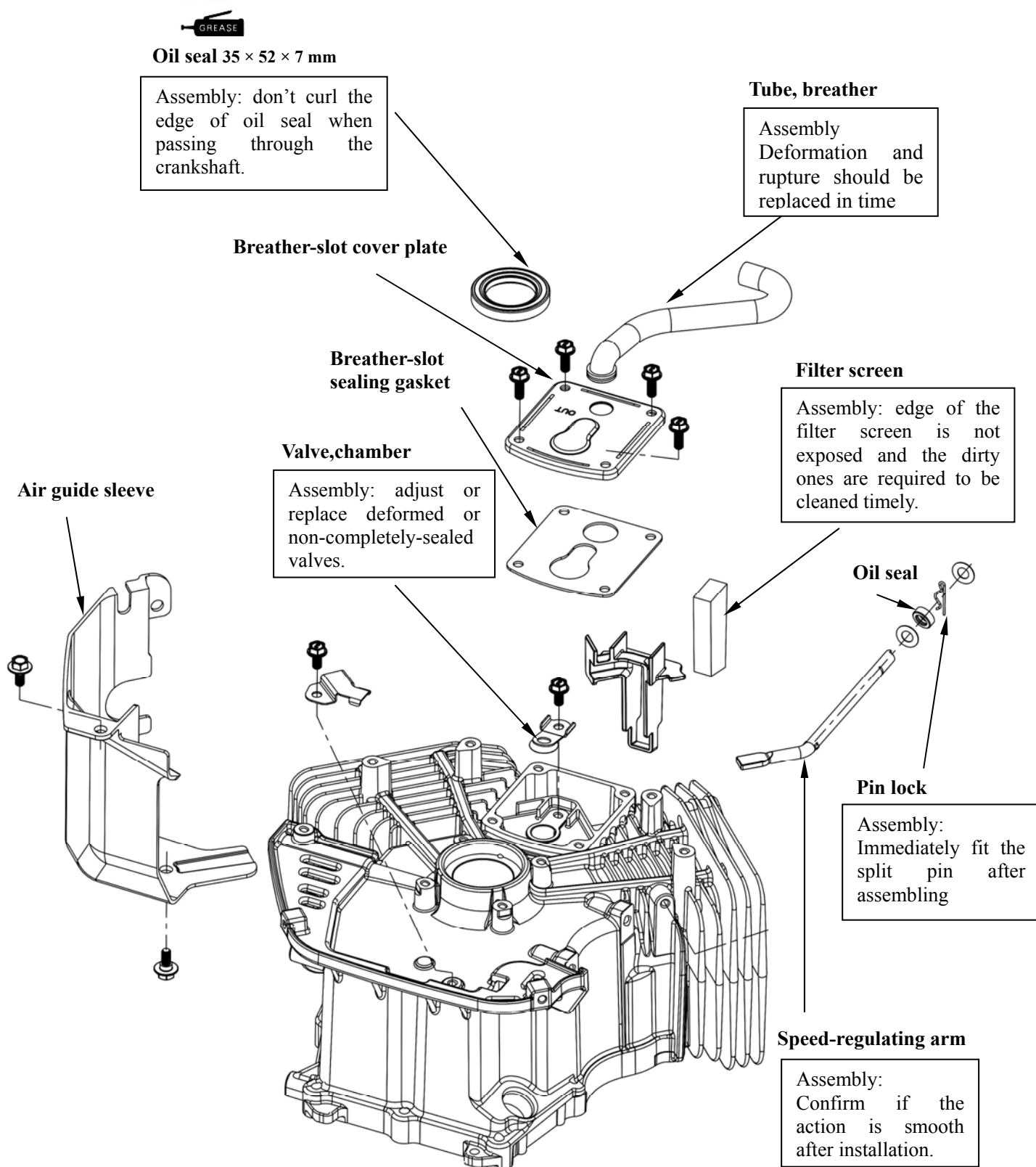

Chapter V Disassembly & Repair

5-2-8 Crankcase cover and governor

Disassembly / reassembly

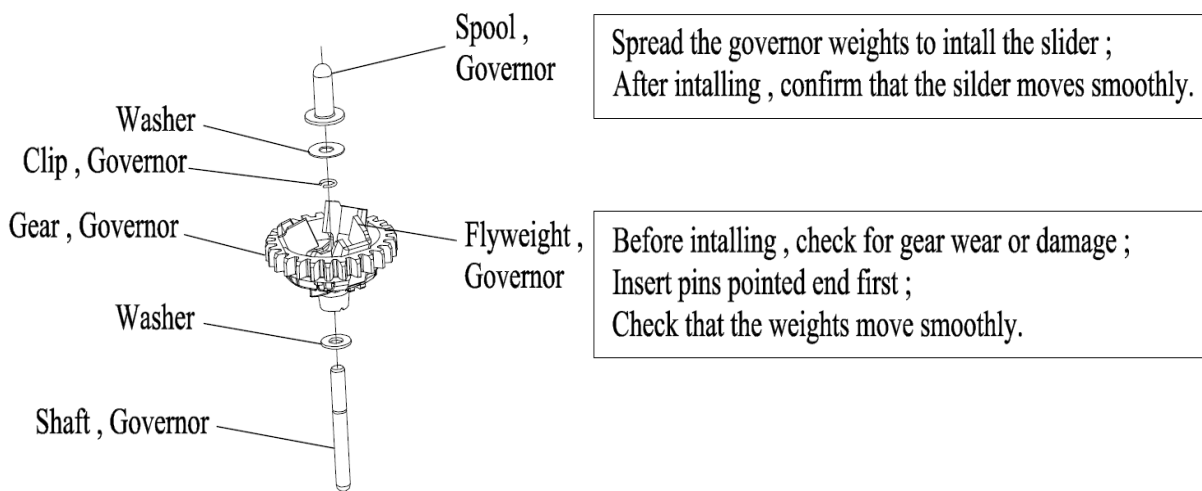

NOTICE:

Check that the governor move smoothly. Speed gear pressing, axial clearance should be guaranteed to 0.05~0.35mm.

Chapter V Disassembly & Repair

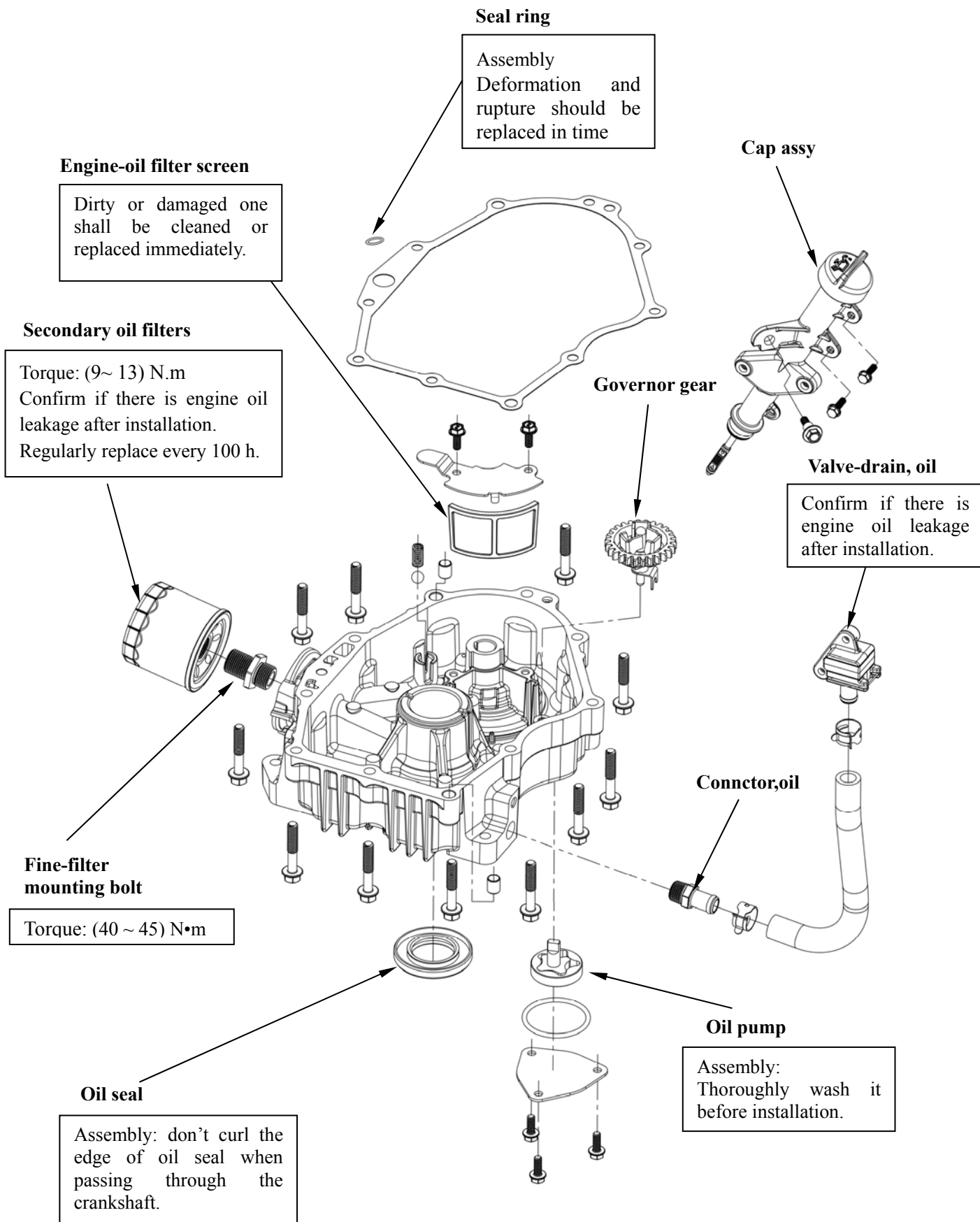

Chapter V Disassembly & Repair

Check

Installation check of oil pump

- 1、 Rotational flexibility of rotator: coat lubricating oil onto rotator and axis prior to assembly; manually rotate the rotational axis after assembly to assure no binding in rotation process.
- 2、 Pumping of oil pump: after assembly, add certain engine oil at the filter screen of the oil inlet for the oil pump, manually rotate the gear of oil pump to assure the oil pump can pump oil, otherwise, re-assemble or replace the oil pump.

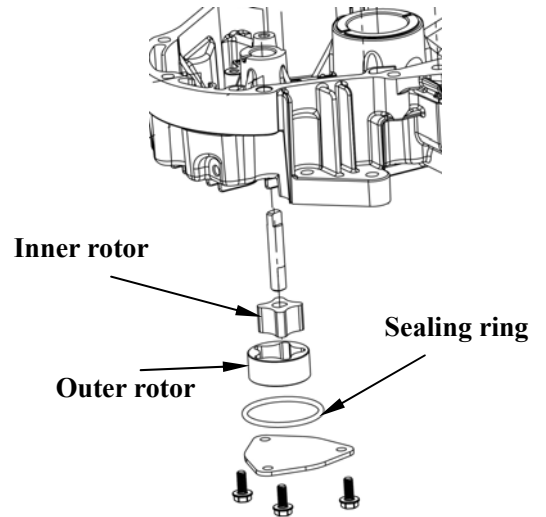

Chapter V Disassembly & Repair

5-2-9 Crankcase, crankshaft and piston

Disassembly/assembly

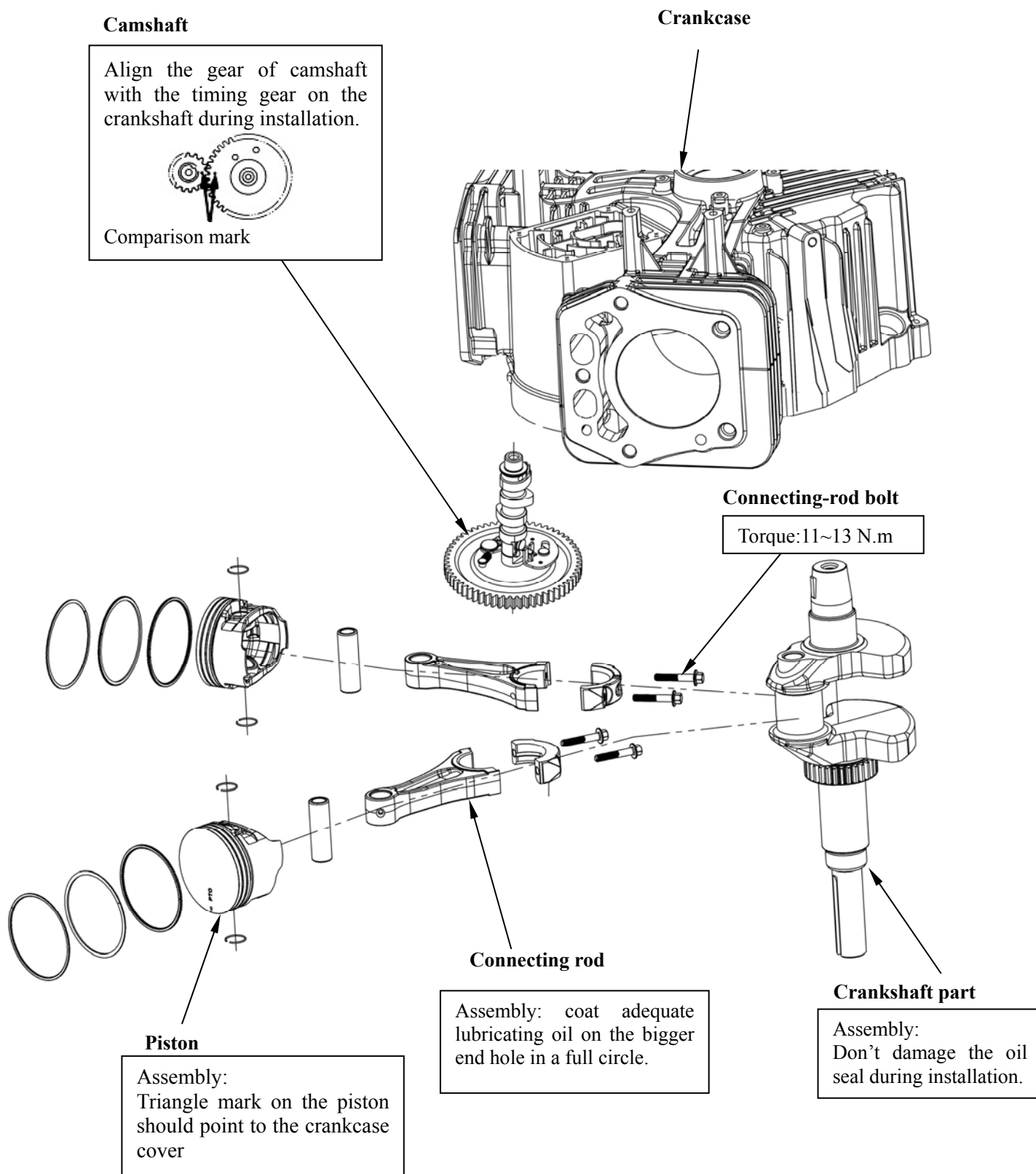

Chapter V Disassembly & Repair

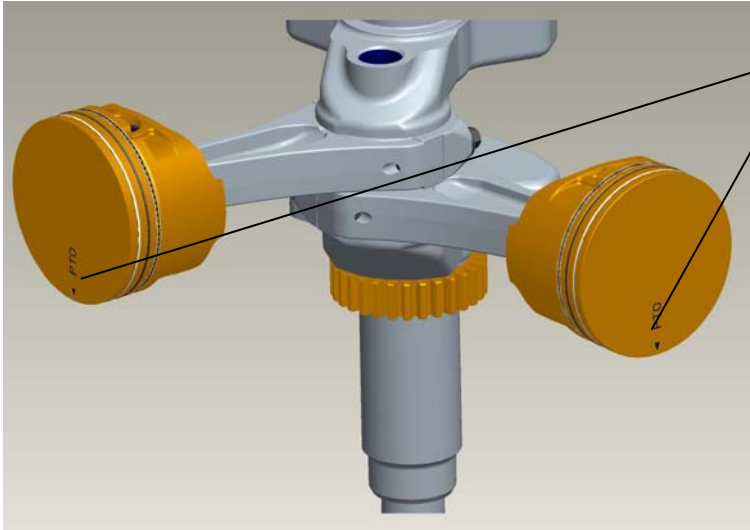

Triangle mark on the piston should point to the crankcase cover

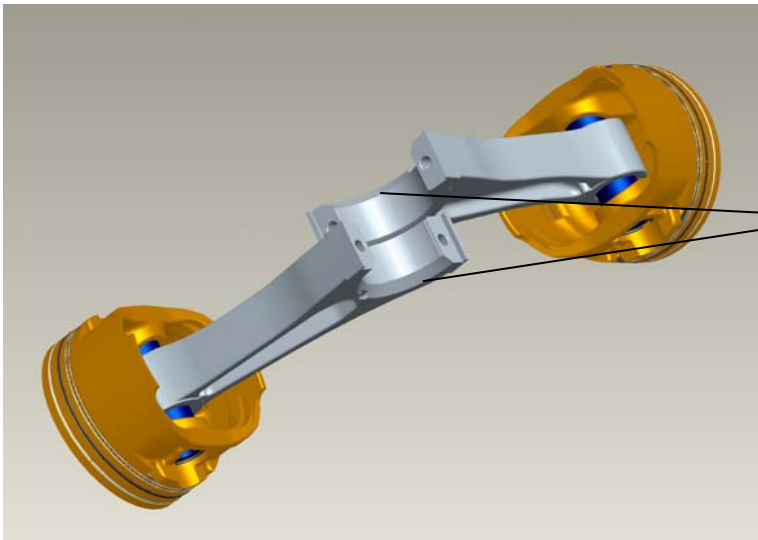

The installation of connecting rod, connecting rod big end hole of the installation of two large chamfer in the opposite direction.

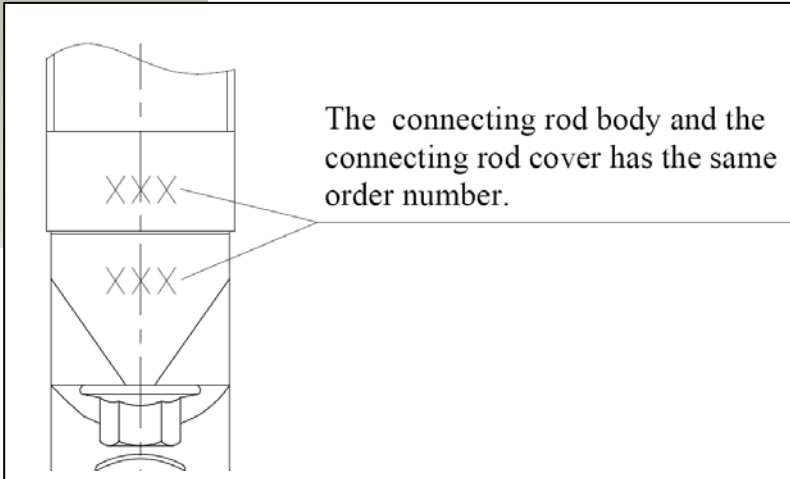
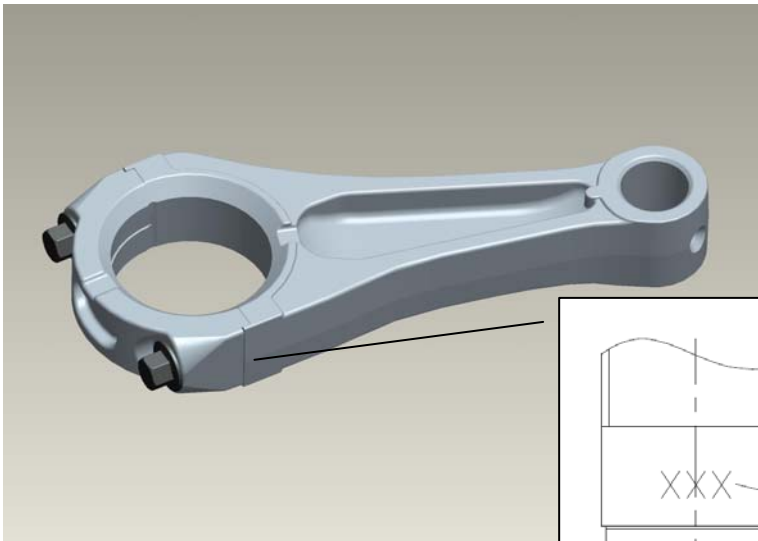

The connecting rod body and the connecting rod cover has the same order number.

Chapter V Disassembly & Repair

Disassembly/assembly

Piston and connecting rod

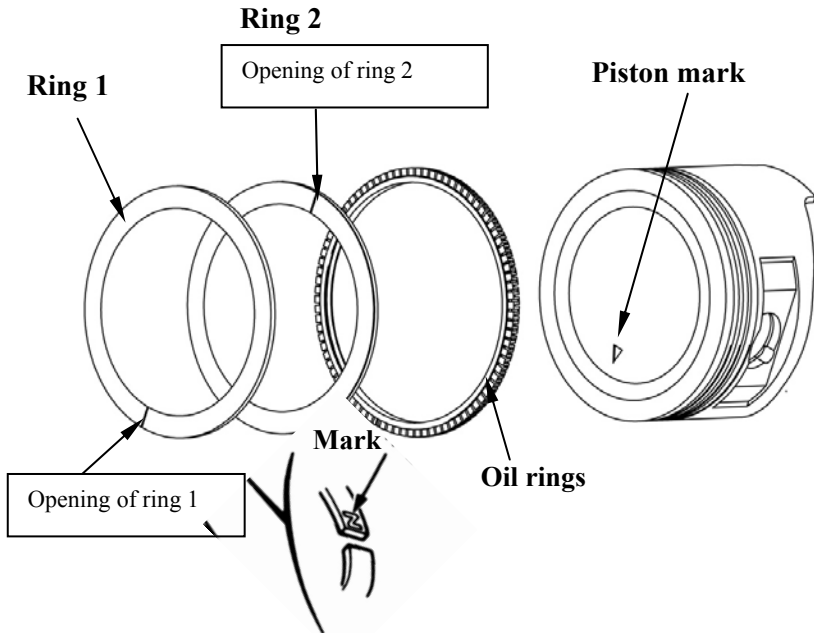

Assembly:

- . Put upward the manufacturer's mark during assembly.
- . Do not misplace the gas rings 1 and 2.
- . Check if the piston ring can rotate flexibly after installation.
- . Avoid the direction of piston pin for each opening of piston ring by staggering for $150^{\circ} \sim 210^{\circ}$.

Note:
Openings of rings 1 and 2 shall be staggered for $150^{\circ} \sim 210^{\circ}$.

Note:
Opening of blade ring of oil ring shall be staggered for $150^{\circ} \sim 210^{\circ}$.

Connecting rod

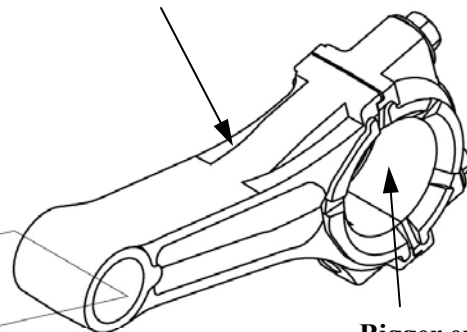

Bigger end hole

Coat adequate lubricating oil on the bigger end hole of the connecting rod in a full circle.

Steel wire retaining ring

Assembly:
Put one end to the slot of the piston, and clamp the other end with the long nose pliers; rotate and install it into the slot. Don't make the opening of the clamp ring face the gap of the piston pin.

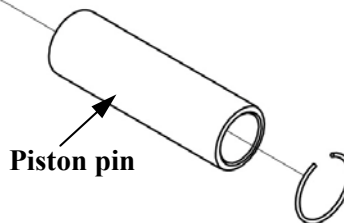
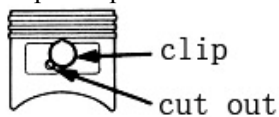

Chapter V Disassembly & Repair

Check

Outer diameter of piston pin

Standard	Maintenance Limit
16.992~16.998 mm	16.95 mm

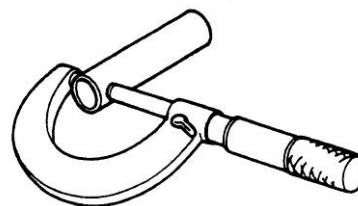

Inner diameter of cylinder

Measure the three points on X and Y axes and record the inner diameter of the cylinder (X axis is perpendicular to crankshaft while Y axis is parallel to crankshaft).

Take the maximum reading as the wear and conical degree of the cylinder.

Model	Standard	Maintenance Limit
LC2P73F	73~73.01 mm	73.1 mm
LC2P76F	76.0~76.01 mm	76.1 mm

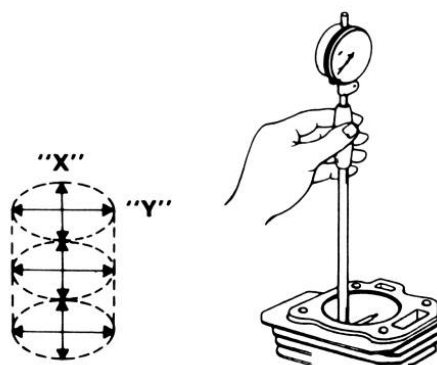

Detection of piston and piston ring

Check the contact between piston and cylinder, defects of ring groove, erosion at the top, crack, etc. It shall be replaced for severe damages (e.g. crack).

Remove carbon deposition

Carbon deposition accumulates at the edge of the top of piston and upper opening of cylinder. Remove carbon deposition prior to detection. Wet the carbon deposition with kerosene, and then remove it with blunt scraper or metallic brush.

Outer diameter of piston skirt

Measure and record the outer diameter of piston skirt at the place 10 mm away from the maximum lower edge of the piston skirt; the measuring direction is perpendicular to the piston pin hole.

Model	Standard	Maintenance Limit
LC2P73F	72.965~72.975 mm	72.755 mm
LC2P76F	75.965~75.975 mm	75.755 mm

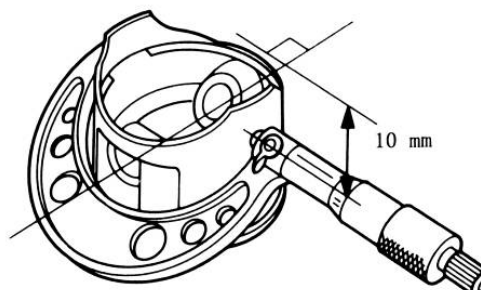

Chapter V Disassembly & Repair

Clearance between piston and cylinder

The difference between the maximum diameter of cylinder and the diameter of the piston skirt is the clearance between piston and cylinder.

Standard	Maintenance Limit
0.025~0.045 mm	0.255 mm

Clearance to the side of piston ring

	Standard	Maintenance Limit
Top/ Second	0.02-0.06 mm	0.11 mm

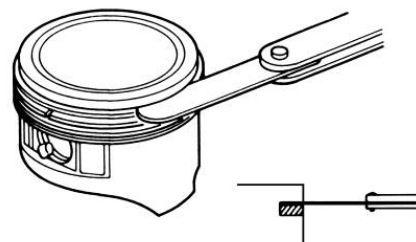

Width of piston ring

	Standard	Maintenance Limit
Top	1.17~1.19mm	1.1 mm
Second	1.17~1.19mm	1.1 mm
Oil ring	1.87~1.97mm	1.8 mm

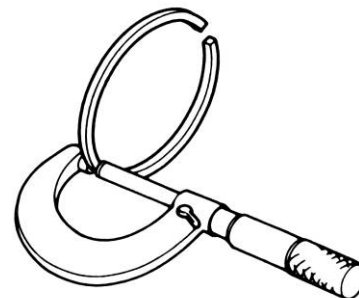

Clearance to the end of piston ring

	Standard	Maintenance Limit
Top/ Second	0.2~0.4 mm	0.45 mm

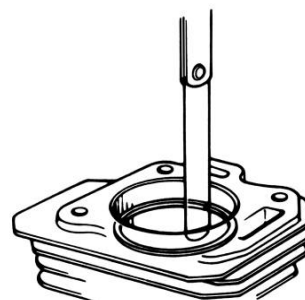

Before measuring the clearance to the end of piston ring, locate the piston ring with the top of the piston to make it not erect in the inner hole of the cylinder.

Inner diameter of piston pin hole

Standard	Maintenance Limit
17.002~17.008 mm	17.12 mm

Clearance between piston pin hole and piston pin

Standard	Maintenance Limit
0.004~0.016 mm	0.029 mm



Chapter V Disassembly & Repair

Detection of connecting rod

The connecting rod shall be scrapped to change a new one when it is bent or warped, or there is abnormal wear to the larger end and small end hole or there is crack of one side.

Inner diameter of the small end of connecting rod

Change the connecting rod if the inner diameter is less than the standard or more than the maintenance limit.

Standard	Maintenance Limit
17.006~17.017 mm	17.05 mm



Inner diameter of the big end of connecting rod

Change the connecting rod if the inner diameter is less than the standard or more than the maintenance limit.

Standard	Maintenance Limit
38.015~38.025 mm	38.065 mm

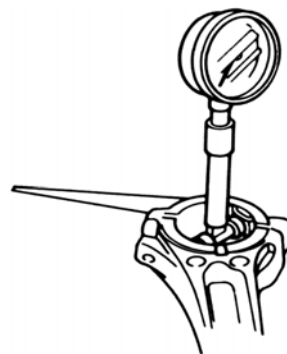

Detection of crankshaft

Conduct 100% inspection to the cleaning condition inside the oil passage prior to the installation of crankshaft and clean the oil passage with blow gun to ensure there are no impurities in the oil passage.

Outer diameter of the crankshaft journal

Standard	Maintenance Limit
37.961mm~37.976 mm	37.92mm

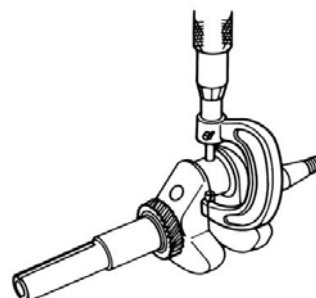

Side clearance of the big end of connecting rod

Standard	Maintenance Limit
0.024mm~0.059mm	0.145mm

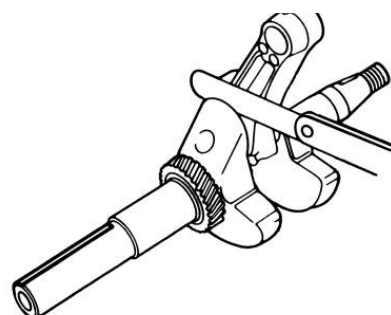

Chapter V Disassembly & Repair

Oil-film clearance of big end of connecting rod (radial direction)

- 1) Clean the surface of crankshaft journal and the inside oil.
- 2) Set plastigauge on crank journal then assemble the connecting rod, and fasten the bolt as per the specified torque.

Fastening torque: 12 N.m±1 N.m

⚠ Note

Don't rotate the crankshaft when fastening the connecting-rod bolt. Calibrate with torque wrench in N+1 way and conduct 100% inspection to the crankshaft to see if it rotates flexibly.

- 3) Disassemble the connecting rod and measure the thickness of plastigauge.

Standard	Maintenance Limit
0.039-0.064 mm	0.083mm

- 4) When the clearance exceeds the maintenance limit, replace the connecting rod and check the clearance again. If the clearance still exceeds the maintenance limit after using new connecting rod, grind the crankshaft journal and use the connecting rod less than the standard value.

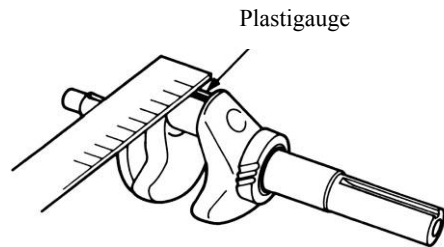
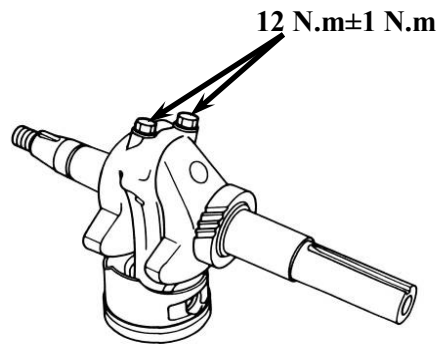

Detection of camshaft

The camshaft is the main engine drive element of valve mechanism of gasoline engine, controlling inlet or exhaust valve to open or close in a regular manner.

For appearance, check whether the cam surface and the height is damaged, whether the camshaft and bearing is loose and worn. If yes, change the whole unit.

Height of camshaft

	Standard	Maintenance Limit
Inlet	29.95~30.05mm	29.75 mm
Exhaust	29.95~30.05mm	29.75mm

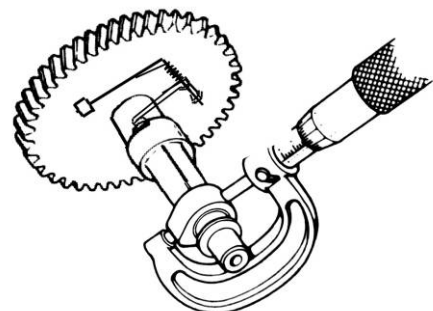

Chapter V Disassembly & Repair

Outer diameter of camshaft

Standard	Maintenance Limit
15.966~15.984mm	15.916mm

Note the position of depression mechanism and check to ensure its flexibility.

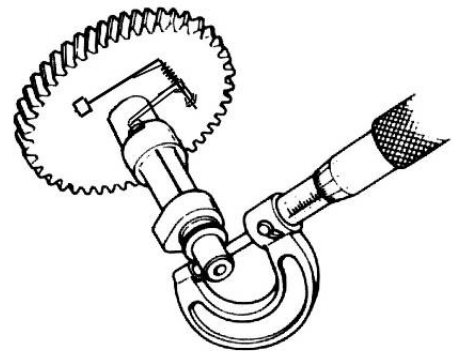

Inner diameter of camshaft bearing hole

Standard	Maintenance Limit
16.0-16.018 mm	16.068 mm

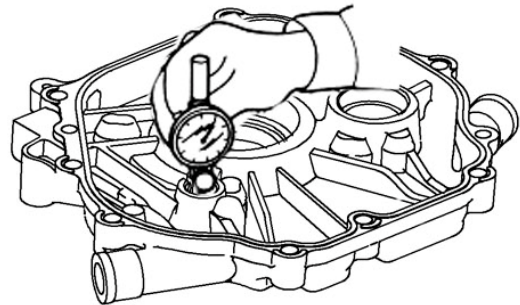



LONCIN MOTOR CO., Ltd.

Add: No.99 Hualong Road, Jiulongpo District, Chongqing, China

Tel: 86 23 8906 7577/7599

Fax: 86 23 8906 7533

Web site: www.loncinengine.com

E-Mail: marketing@loncinengine.com

Other ManualsLib Projects



www.manualslib.com



www.manualslib.de



www.manualslib.es



www.manualslib.fr



www.manualslib.nl



www.manualslib.mx



www.manualslib.tech 30+ Languages